



Handling Instructions for Bearings

NSK



NSK

Handling Instructions for Bearings

For Proper Handling of Rolling Bearings

Contents

| | |
|----------|---|
| 1 | Precautions for Proper Handling of Rolling Bearings .. 1 |
| 2 | Mounting 1 |
| 2.1 | Fits with Shafts 1 |
| 2.1.1 | Fits and Clearances 1 |
| 2.1.2 | Press Fitting Force and Heating Temperature for Tight Fitting 4 |
| 2.1.3 | Fitting Work 5 |
| 2.1.4 | Mounting Bearings with Tapered Bores 7 |
| 2.2 | Mounting in a Housing 7 |
| 2.3 | Mounting with Preload Applications 9 |
| 2.3.1 | Preload for Radial Bearings 9 |
| 2.3.2 | Preload for Thrust Bearings 11 |
| 2.4 | General Mounting Precautions 12 |
| 2.5 | Lubrication 13 |
| 2.6 | Test Operation 14 |
| 3 | Maintenance and Inspection 16 |
| 3.1 | Procedures of Maintenance and Inspection 16 |
| 3.2 | Lubrication Method 16 |
| 3.2.1 | Grease Lubrication 16 |
| 3.2.2 | Oil Lubrication 17 |
| 3.3 | Bearing Failure 18 |
| 4 | Dismounting 22 |
| 4.1 | Dismounting Outer Rings 22 |
| 4.2 | Dismounting Inner Rings 22 |
| 4.3 | Bearing Cleaning 23 |
| 4.4 | Bearing Inspection 24 |
| 5 | Bearing Storage 24 |
| 6 | Appendices 25 |

1 Precautions for Proper Handling of Rolling Bearings

Rolling bearings are used under various operating conditions with a wide variety of light to heavy loads. Since they are manufactured to a high level of accuracy, they must be handled carefully and properly; the purpose for which they are used is just as important as careful handling.

Incorrect mounting and improper handling are the most common causes of premature failure. Consequently, it is clear that proper handling, as well as appropriate selection and usage, are essential. Instructions for the proper handling of rolling bearings are summarized as follows:

- (1) Keep bearings and related components clean.
- (2) Confirm that the dimensions and finish of related components are correct for the desired use.
- (3) Keep bearings free from harmful substances, including foreign particles and moisture.
- (4) Be sure to mount bearings in compliance with their designed purpose and specified operating conditions.
- (5) Use the proper tools for mounting and dismounting.

(6) Exercise care to not damage or distort bearings in the course of mounting and dismounting.

(7) Use the correct quantities of the appropriate lubricant.

(8) Keep hands as clean as possible when handling bearings to prevent corrosion. Wearing gloves, if possible, is recommended.

Although sophisticated devices are not necessarily required for handling bearings, proper tools should be used depending on specific circumstances to facilitate work operations and ensure flawless performance. Obviously, engineers who engage in design and inspection must also be well versed in the proper handling and mounting methods in conformity with the intended use of the bearings.

The goals of proper handling are to protect the bearings from any potential damage and ensure they serve their intended uses as effectively as possible.

2 Mounting

2.1 Fits with Shafts

2.1.1 Fits and Clearances

Standard bearings with cylindrical bores are often mounted by providing interference fit to the corresponding shafts. At the same time, significant force is required to press-fit the inner ring on the shaft. A certain degree of interference fit has been provided for mounting, as the inner ring may expand somewhat, generally reducing the amount of clearance in proportion to the expansion of the inner ring.

Although clearance for tapered roller bearings is adjustable after they are mounted, clearance adjustments cannot be made for ball bearings and cylindrical roller bearings. Therefore, bearings with sufficient clearance must be selected according to the level of interference. Bearings are generally manufactured based on a CN clearance suited for normal load conditions. To the extent that an interference fit is larger than the CN clearance, bearings with a larger

clearance (C3, C4, etc.) must be selected.

In general, the decrease in clearance resulting from the fitting between the inner ring and the shaft may be expressed by the following equations (1) and (2):

For machined shafts;

$$\delta_f = k \cdot \Delta d = k \frac{d}{d+3} \Delta d_a \dots \dots \dots (1)$$

For ground shafts;

$$\delta_f = k \cdot \Delta d = k \frac{d}{d+2} \Delta d_a \dots \dots \dots (2)$$

Where

δ_f : Decrease in clearance due to fitting (mm)

Δd : Effective interference (mm)

Δd_a : Apparent interference for measurement (mm)

k : $d/D_i \cong 0.70$ to 0.90

d : Bearing nominal bore diameter (mm)

D_i : Raceway diameter of inner ring (mm)

Table 1 Fits of Radial Bearings with Shafts

■ Fits of Radial Bearings with Shafts

| Load Conditions | Examples | Shaft Diameter (mm) | | | Tolerance of Shaft | Remarks | | |
|---|--|--|--|---------------------------|--------------------|--|---|--|
| | | Ball Bearings | Cylindrical Roller Bearings Tapered Roller Bearings | Spherical Roller Bearings | | | | |
| Radial Bearings with Cylindrical Bores | | | | | | | | |
| Rotating Outer Ring Load | Easy axial displacement of inner ring on shaft desirable | Wheels on stationary axles | All shaft diameters | | | g6 | Use g5 and h5 where accuracy is required. In case of large bearings, f6 can be used to allow easy axial movement. | |
| | Easy axial displacement of inner ring on shaft unnecessary | Tension pulleys, rope sheaves | | | | h6 | | |
| Rotating Inner Ring Load or Direction of Load Indeterminate | Light loads or variable loads ($\leq 0.06 C_r$ (1)) | Electrical home appliances, pumps, blowers, transport vehicles, precision machinery, machine tools | ≤ 18 | — | — | js5 | Use class 5 and high precision bearings where accuracy is required. For high precision ball bearings with bore diameter shorter than 18 mm, use h5. | |
| | | | 18~100 | ≤ 40 | — | js6 (j6) | | |
| | | | 100~200 | 40~140 | — | k6 | | |
| | | | — | 140~200 | — | m6 | | |
| | | | ≤ 18 | — | — | js5-6 (j5-6) | | k6 and m6 can be used for single-row tapered roller bearings and single-row angular contact ball bearings instead of k5 and m5 |
| | | | 18~100 | ≤ 40 | ≤ 40 | k5-6 | | |
| | 100~140 | 40~100 | 40~65 | m5-6 | | | | |
| | 140~200 | 100~140 | 65~100 | m6 | | | | |
| | 200~280 | 140~200 | 100~140 | n6 | | | | |
| | — | 200~400 | 140~280 | p6 | | | | |
| | Heavy loads or shock loads ($> 0.13 C_r$ (1)) | Railway axleboxes, industrial vehicles, traction motors, construction equipment, crushers | | — | 50~140 | 50~100 | n6 | More than CN bearing internal clearance is necessary. |
| | | | | — | 140~200 | 100~140 | p6 | |
| — | | | | > 200 | 140~200 | r6 | | |
| — | | | | — | 200~500 | r7 | | |
| — | | | | — | > 500 | r7 | | |
| — | | | | — | > 500 | r7 | | |
| Central axial load only | Used part of each type of bearings | All shaft diameters | | | js6 (j6) | — | | |
| Radial Bearings with Tapered Bores and Sleeves | | | | | | | | |
| All type of loading | General bearing applications | All shaft diameters | | | h9/IT5 (2) | IT5 and IT7 mean that the deviation of the shaft from its true geometric form, e.g. roundness and cylindricity should be within the tolerances of IT5 and IT7, respectively. | | |
| | Transmission shafts, woodworking spindles | | | | h10/IT7 (2) | | | |

Note (1) C_r represents the basic load rating of the bearing.

(2) Refer to Appendix Table 3 (page 29) for values of IT.

Remarks This table is applicable only to solid steel shafts.

■ Fits of Thrust Bearings with Shafts

| Load Conditions | Examples | Shaft Diameter (mm) | Tolerance of Shaft | Remarks | | |
|--|----------------------------|---|--|---------|------------|----|
| Central axial load only | Main shafts of lathes | All shaft diameters | h6 or js6 (j6) | | | |
| Combined radial and axial loads (Spherical thrust roller bearings) | Stationary inner ring load | Cone crushers | js6 (j6) | — | | |
| | | Rotating inner ring load or direction of load indeterminate | Paper pulp refiners, plastic extruders | | ≤ 200 | k6 |
| | | | | | 200~400 | m6 |
| | | > 400 | n6 | | | |

Table 2 Fits of Bearings with Housings

■ Fits of Radial Bearings with Housings

| Load Conditions | | Examples | Tolerances for Housing bores | Axial Displacement of Outer Ring | Remarks | |
|-------------------------|---------------------------------|--|--|----------------------------------|----------------------|--|
| Solid Housings | Rotating outer ring load | Heavy loads on bearing in thin-walled housing or heavy shock loads | Automotive wheel hubs (roller bearings) Crane travelling wheels | P7 | Impossible | — |
| | | Normal or heavy loads | Automotive wheel hubs (ball bearings) Vibrating screens | N7 | | |
| | | Light or variable loads | Conveyor rollers Rope sheaves Tension pulleys | M7 | | |
| Solid or Split Housings | Direction of load indeterminate | Heavy shock loads | Traction motors | K7 | Generally impossible | If axial displacement of the outer ring is not required. |
| | | Normal or heavy loads | Pumps Crankshaft main bearings Medium and large mortars | | | |
| | | Normal or light loads | | | | |
| | Rotating inner ring load | Loads of all kinds | General bearing applications Railway axleboxes | H7 | Possible | — |
| | | Normal or light loads | Plummer blocks | H8 | | |
| | | High temperature rise of inner ring through shaft | Paper dryers | G7 | | |
| Solid Housings | Direction of load indeterminate | Accurate running desirable under normal or light loads | Grinding spindle real ball bearings Grinding centrifugal compressor free bearings | JS6 (J6) | Possible | — |
| | | | Grinding spindle front ball bearings Grinding centrifugal compressor fixed bearings | K6 | | |
| | Rotating inner ring load | Accurate running and high rigidity desirable under variable loads | Cylindrical roller bearings for machine tool main spindle | M6 or N6 | Fixed | |
| | | Minimum noise is required | Electrical home appliances | H6 | Easily possible | — |

Remarks 1. This table is applicable to cast iron and steel housings. For housings made of light alloys, the interference should be tighter than those in this table.
2. Refer to NSK catalogs for special fittings such as drawn cup needle.

■ Fits of Thrust Bearings with Housings

| Load Conditions | Bearing Types | Tolerances for Housing Bores | Remarks |
|---------------------------------|---|---------------------------------|---|
| Axial loads only | Thrust Ball Bearings | Clearance $\geq 0.25\text{mm}$ | For general applications |
| | | H8 | When precision is required |
| | Spherical Thrust Roller Bearings Steep Angle Tapered Roller Bearings | Outer ring has radial clearance | When radial loads are sustained by other bearings |
| Combined radial and axial loads | Stationary outer ring loads | H7 or JS7 (J7) | — |
| | | K7 | Normal loads |
| | | M7 | Relatively heavy radial loads |

Therefore, 70% to 90% of the interference appears as reduction in clearance. (Smaller reduction in clearance is adopted for bearings of diameter series 4.)

Moreover, the difference in operating temperature between inner and outer rings ranges from 5 °C to 10 °C. However, this temperature difference will exceed that range if the inner ring's temperature rises or the outer ring is cooled.

Reduction in clearance due to temperature difference between inner and outer rings:

$$\delta_t \doteq a \cdot \Delta t \cdot D_e \dots \dots \dots (3)$$

Where

δ_t : Reduction in radial clearance due to temperature difference between inner and outer rings (mm)

a : Coefficient of linear expansion of bearing steel $\doteq 12.5 \times 10^{-6} (1/^\circ\text{C})$

Δt : Temperature difference between inner and outer rings (°C)

D_e : Outer ring raceway diameter (mm)

$$\text{Rolling Bearing} \doteq \frac{1}{4} (3D + d)$$

$$\text{Ball Bearing} \doteq \frac{1}{5} (4D + d)$$

d : Nominal bearing bore diameter (mm)

D : Nominal bearing outside diameter (mm)

Tables 1 and 2 provide examples of how the degree of these fits is determined based on load and temperature conditions, etc. Bearings with C3 or C4 clearance (larger than CN clearance) must be used depending on the degree of fit and temperature conditions.

2.1.2 Press Fitting Force and Heating Temperature for Tight Fitting

When attaching the inner ring firmly to the shaft, the force to press-fit an inner ring in the axial direction varies depending on interference and shaft diameter. However, the required force rises as surface pressure on the fitted surface and friction coefficient increase. When a stronger press fitting force is required, the inner ring is usually expanded by heating in oil before mounting, but in some cases, the ring is press-fitted using a press or similar tool while measuring the degree of interference as measured in the press fitting force.

The surface pressure p_m , and press fitting force or withdrawal force of the fitted surface, which are applied to a solid shaft, can be expressed by the following equations (4) and (5):

$$p_m = \frac{1 - k^2}{2} \cdot \frac{\Delta d}{d} \cdot E \dots \dots \dots (4)$$

$$K = \mu p_m \pi d B$$

$$= \frac{1}{2} \mu E \pi B (1 - k^2) \Delta d \dots \dots \dots (5)$$

Table 3 Values of μ

| Example of application | μ value (average) |
|---|-----------------------|
| Press-fitting inner ring to cylindrical shaft | 0.12 |
| Withdrawing inner ring from cylindrical shaft | 0.18 |
| Press-fitting inner ring to cylindrical shaft | 0.165 |
| Press-fitting inner ring to cylindrical shaft | 0.135 |
| Press-fitting sleeve onto the area between shaft and bearing's tapered hole | 0.30 |
| Withdrawing sleeve from the area between shaft and bearing's tapered hole | 0.33 |

Where

$k : d/D_i$

d : Nominal bearing bore diameter (mm)

D_i : Raceway diameter of inner ring (mm)

B : Nominal inner ring width (mm)

Δd : Effective interference (mm)

E : Modulus of longitudinal elasticity = 208 000 MPa

μ : Friction coefficient of the fitted surface

Friction on the fitted surface differs substantially depending on the fitted-surface conditions. In general, the values listed in the Table 3 can apply to the values of μ . Also, the value of $(1 - k^2)$ with respect to each ratio D/d of outside diameter to bore diameter of a bearing can be approximately expressed as shown in Table 4.

This is how to calculate the press fitting force to press an inner ring onto the shaft. In many cases, however, it is easier to mount the inner ring in place after heating it in oil to expand it. Although the applicable temperatures vary according to interference and shaft diameter, it is recommended to heat the bearing at 120 °C or lower whenever possible since the hardness of the bearing will decrease when heated to 150 °C or higher. Fig. 1 shows the heating temperature and shaft inner diameter expansion with respect to shaft diameter, in which the required heating temperature differences can be found, since it also shows the maximum interference of various fits.

In actual fitting work, as the bearing cools, it is cannot be easily mounted on the shaft. Therefore, heat the bearing to 20 °C to 30 °C higher than the lowest temperature

Table 4 Values of $(1 - k^2)$

| D/d | $(1 - k^2)$ |
|-------|-------------|
| 1.5 | 0.25 |
| 2.0 | 0.41 |
| 2.5 | 0.52 |
| 3.0 | 0.61 |
| 3.5 | 0.67 |

D : Nominal outside diameter, d : Nominal bore diameter

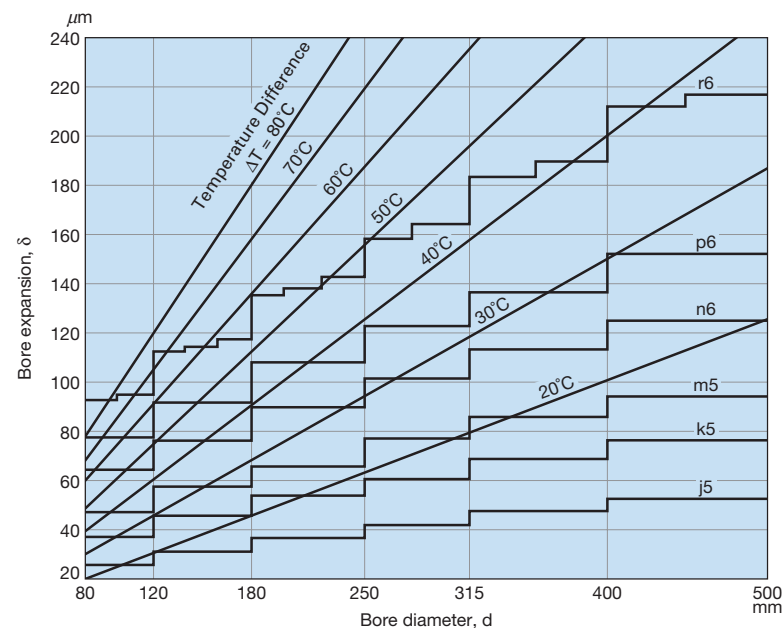

Fig. 1 Temperature and Thermal Expansion of Inner Ring

required for mounting. It is usually recommended that the bearing be immersed in oil to heat for 20 minutes. For example, when a bearing with a bore diameter of 120 mm is mounted with fit n6, the maximum interference is 65 μm. In this case, the required heating temperature may be room temperature + 50 °C as shown in Fig. 1, whereas the temperature must be raised an additional 20 °C to 30 °C in order to easily press it onto the shaft. Consequently, the required heating temperature can be seen to be room temperature + 70 °C to 80 °C.

Press fitting force and shrink fit for tight fitting have already been briefly discussed. However, excessive interference can sometimes produce abnormally large stress in the inner ring, which may cause the inner ring to crack or be otherwise damaged. Of the stress produced in the inner ring, the circumferential stress on the fitted surface in its inner diameter is the largest, and its magnitude can be expressed by equation (6) as shown below.

$$\sigma_{tmax} = p_m \frac{1+k^2}{1-k^2} \dots \dots \dots (6)$$

where,

p_m : Surface pressure (MPa)
 k : d/D_i

As a general rule, it is desirable to choose a fit for which the maximum stress value may be set to 98 MPa or less for bearing steel or, in the worst case, to 127 MPa or less.

2.1.3 Fitting Work

The inner ring is usually mounted on a shaft by means of press fitting or shrink fitting. Press fitting, however, requires a large force. The required force for press fitting can be determined by the aforementioned equation (5). During press fitting work, brinelling indentations may be caused on the raceway surfaces by rolling elements (balls

or rollers) if force is applied to the outer ring. Furthermore, direct shock applied to the small ribs of the inner ring may cause the ring to crack. At the same time, no force should be applied to the cage. Therefore, exercise considerable care when performing press fitting work.

Since only a small press fitting force is required for medium- or small-sized bearings with a smaller interference, the inner ring can be pressed onto the shaft corresponding to the bearings at room temperature. As shown in Fig. 2, tap the brass bar on the lateral face of the inner ring, then hammer it to press-fit the ring onto the shaft. At this point, the tip of the brass bar, which has been cut crosswise in advance, comes into contact with the inner ring's lateral face, so that the outside face of the ring's lateral face will not be struck and the ring will be brought into firm, proper contact with the shaft shoulder. Take care not to allow brass chips to enter the bearings.

A more effective method involves using a tubular fitting tool (Fig. 3) made of mild steel that contacts the entire side face of inner ring. Using this tool, press fitting can be done while exerting a heavy but non-damaging impact on the ring.

Using a press, compressed air, or hydraulic pressure, facilitates parallel push-in and enables grasping press-fit pressure for proper mounting. Consequently, these tools are useful since the interference can be checked to see if it is too tight or too loose.

Before conducting press fitting work, a high-viscosity oil, preferably an extreme-pressure lubricant, must be applied to the inner surface of the inner ring and the outer surface of the shaft. Also note that applying a lubricant made of molybdenum disulfide (MoS₂), in a paste form, to the areas for press fitting work prevents scoring and facilitates easier dismounting because it

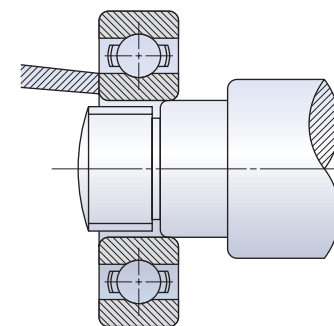

Fig. 2 Mounting of Bearing

prevents the bearing from adhering to the fitted surface during dismounting. Shrink fitting is recommended as an easy mounting method for bearings with tighter interference. Heating temperature can be determined from Fig. 1 according to the specific bearing dimension and the intended interference. A high-quality mineral oil should be used for the heating oil.

The oil bath should be large enough to accommodate two to five bearings, with a sufficient amount of oil to completely cover the bearings. Precautions for use of the oil bath are shown in Fig. 4. Be sure to use a wire net or equivalent device in the bath to support the bearings in the oil without allowing them to directly contact either the heater or the bottom of the bath. For easy handling, place a long bar across the top of the oil bath with an attached hook from which to suspend the bearings. When tight-fitting inner rings are used for cylindrical roller bearings for rolling mills, as well as for axle bearings for railway rolling stock, a stronger press fitting force and withdrawal force are required for mounting and dismounting. For this reason, the bearings or shafts may be damaged due to operating difficulties under normal working conditions. For cylindrical roller bearings whose inner rings are not provided with ribs, it is recommended to use induction current to heat and expand the inner rings for mounting and dismounting to speed up the operation. Using this mechanism, NSK has devised a heating-type mounting/dismounting device that can be powered by an AC factory power supply with commercial frequency, and markets it for various industrial fields. Moreover, NSK has also made commercially available a bearing heater, as shown in Fig. 5, for heating a single unit, such as a small bearing.

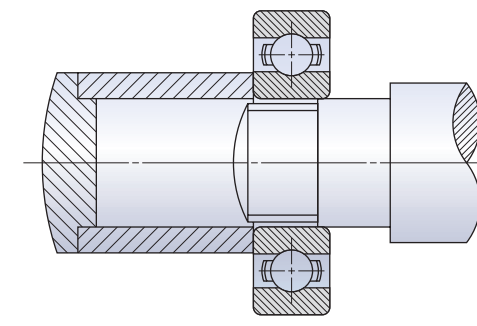

Fig. 3 Mounting of Bearing

A bearing attached to a shaft cools rapidly, and after heating, an expanded bearing shrinks in a crosswise direction. In some cases, therefore, in order to avoid a clearance between the inner ring and shoulder, press the bearings firmly against the shoulder by means of a shaft nut or other appropriate tool.

After mounting a bearing in place, cool it and apply lubricant to its inner and outer surfaces. At that point, make sure the bearing is free of any dirt.

Except when preload is applied to a bearing, a clearance is usually needed for the bearing after mounting; therefore, confirm that the bearing rotates smoothly. For roller bearings, clearance can be measured using a clearance gauge.

Since the inner ring can be separated from the outer ring in cylindrical roller bearings, the outer ring must be removed when mounting the inner ring. Avoid applying undue force in the later stage at which the outer ring is fit to the inner ring, which is attached to the shaft, since the rollers and raceway may be easily damaged. This kind of damage should be avoided because it may result in noise and premature failure. Also, roller bearings must be compatible. Consequently, confirm compatibility in advance, and take special care to avoid mistakenly collating incompatible types in combinations.

Although there is no problem with a mounting in which there is a loose fit with the shaft, clearance between the shaft and the inner ring must be minimal.

Usually, the fit between the inner ring and shaft of a thrust bearing should be about js6 (j6). Some clearance is usually provided, except for machine tools, which require a higher degree of accuracy.

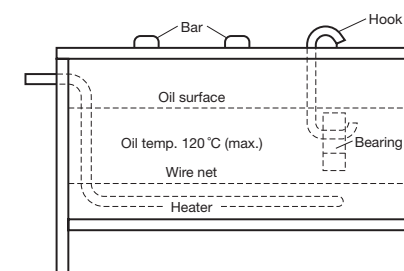

Fig. 4 Oil heating bath

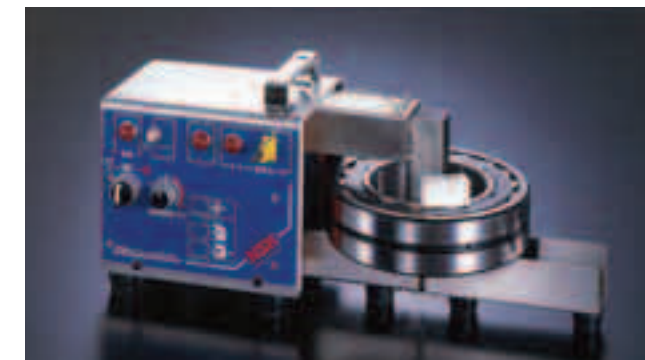

Fig. 5 Heating by bearing heater

2.1.4 Mounting Bearings with Tapered Bores

Bearings with tapered bores are mounted in place using adapter sleeves or withdrawal sleeves, or directly on tapered shafts. The degree of fit is determined by reduction in clearance and push-in amount of the sleeves (or bearings).

For spherical roller bearings, a decrease in clearance during mounting is usually measured by a clearance gauge. The reduction in the clearance and residual clearance after mounting are shown in Table 5.

Spherical roller bearings with tapered bores have generally been manufactured taking into account the reduction in clearance as shown in Table 5. When a very large load will be applied, increase the reduction in clearance by about 20% more than the corresponding listing in Table 5.

In some cases, the push-in amount (axial movement) of the inner ring or withdrawal sleeve is measured instead of directly measuring the reduction in clearance.

However, since it is difficult to determine the initial measurement position, it is safer to directly measure the reduction in clearance.

When a clearance gauge cannot be used for small roller bearings because of the small clearance after mounting them in position, the amount of axial movement must be measured instead of the reduction in clearance. Also, in cases where a large bearing is mounted in such a way that the bearing is heated in oil to expand it to ease mounting, axial movement must also be measured. In this case, the bearing should be initially mounted on the shaft before it is heated and this initial position measured, then the final mounting position can be determined by the amount of axial movement from the initial mounting position after the bearing has been heated. At this stage, the intended reduction in clearance must be confirmed by measuring the initial clearance prior to heating and the final clearance after cooling.

2.2 Mounting in a Housing

Bearings are usually mounted in housings after they have been attached to a shaft. Mounting methods and precautions vary depending on such factors as housing design, fit, and the configuration of horizontal and vertical shafts. The general information discussed in this section should apply to all applications.

The fit between the housing and the outer ring is determined based on load conditions, surface roughness, material hardness, etc. However, if the actual fit is tighter than specified, modifications must be manually performed through operations such as grinding. When the only method for enlarging a housing is to use a scraper, exercise care to avoid deforming the bearing seat into an oval shape or slope.

For a split housing, avoid inserting a thin shim between the upper and lower parts to loosen the fit. In fact, when

the fit is too loose, the insertion of a sheet of paper or metal foil into the area between the housing and the outer ring must be avoided by all means. Only when absolutely necessary, the housing may be modified by plating its inner planes or inserting a bushing so that the housing dimensions can be corrected to meet the specified requirements.

When mounting a housing, do not allow labyrinth seals and other components to rub against each other. Take measures to avoid applying excessive load or eccentric load to the bearing, which may result from improper mounting on the base or defective joints.

Select only one of the bearings to be laid to serve as the fixed-end bearing for fixing and maintaining the mounted bearings in the exact position in an axial direction. For the fixed-end bearing, choose a type of bearing that can bear both radial and axial loads.

Bearings other than the fixed-end bearing should function as free-end bearings on which only radial load can be applied, to relieve expansion and contraction of the shaft due to temperature change. They should also be used to adjust the mounting position in the axial direction.

Unless adequate measures are taken to prevent shaft shrinkage due to temperature changes, abnormal axial load will be applied on the bearings, resulting in premature failure.

Cylindrical roller bearings (NU or N type), in which the inner ring can be separated from the outer ring and which can also move in the axial direction, are suitable for free-end bearings. The use of these types of bearings often increases the ease of mounting and dismounting procedures.

If non-separable bearings are used as free-end bearings, the outer ring and housing should have a loose fit to allow for shaft expansion during operation and to allow for the expansion of the bearings. This can sometimes be accommodated away from the fitted surface between the inner ring and the shaft.

If the distance between bearings is short and shaft shrinkage has less effect on the bearings, use angular contact ball bearings and tapered roller bearings or other types of bearings which can handle the application of axial load in only one direction, and mount them face-to-face or back-to-back to form a duplex set. The axial clearance (movement in axial direction) after mounting should be adjusted with a nut or a shim.

When mounting an outer ring with a tighter fit, use a tubular attachment tool made of mild steel as shown in Fig. 7. Should either the outer or inner rings be mounted with a tight fit and either the inner ring is already mounted on the shaft or the outer ring is already attached to a bearing housing, use tools such as shown in Figs. 8 and 9 to avoid the possible impact of press fitting on a bearing ring through the rolling elements. Furthermore, be sure to use an appropriate method to avoid applying impact load on a bearing when mounting a joint, for example, after having mounted the bearing on a shaft with its housing.

Table 5 Mounting Spherical Roller Bearings with Tapered Bores

Units: mm

| Bearing Bore Diameter <i>d</i> | | Reduction in Radial Clearance | | Axial Movement | | | | Minimum Permissible Residual Clearance | |
|-----------------------------------|-------|-------------------------------|-------|----------------|------|------------|------|--|-------|
| | | | | Taper 1:12 | | Taper 1:30 | | CN | C3 |
| over | incl. | min | max | min | max | min | max | | |
| 30 | 40 | 0.025 | 0.030 | 0.40 | 0.45 | — | — | 0.010 | 0.025 |
| 40 | 50 | 0.030 | 0.035 | 0.45 | 0.55 | — | — | 0.015 | 0.030 |
| 50 | 65 | 0.030 | 0.035 | 0.45 | 0.55 | — | — | 0.025 | 0.035 |
| 65 | 80 | 0.040 | 0.045 | 0.60 | 0.70 | — | — | 0.030 | 0.040 |
| 80 | 100 | 0.045 | 0.055 | 0.70 | 0.85 | 1.75 | 2.15 | 0.035 | 0.050 |
| 100 | 120 | 0.050 | 0.060 | 0.75 | 0.90 | 1.9 | 2.25 | 0.045 | 0.065 |
| 120 | 140 | 0.060 | 0.070 | 0.90 | 1.1 | 2.25 | 2.75 | 0.055 | 0.080 |
| 140 | 160 | 0.065 | 0.080 | 1.0 | 1.3 | 2.5 | 3.25 | 0.060 | 0.100 |
| 160 | 180 | 0.070 | 0.090 | 1.1 | 1.4 | 2.75 | 3.5 | 0.070 | 0.110 |
| 180 | 200 | 0.080 | 0.100 | 1.3 | 1.6 | 3.25 | 4.0 | 0.070 | 0.110 |
| 200 | 225 | 0.090 | 0.110 | 1.4 | 1.7 | 3.5 | 4.25 | 0.080 | 0.130 |
| 225 | 250 | 0.100 | 0.120 | 1.6 | 1.9 | 4.0 | 4.75 | 0.090 | 0.140 |
| 250 | 280 | 0.110 | 0.140 | 1.7 | 2.2 | 4.25 | 5.5 | 0.100 | 0.150 |
| 280 | 315 | 0.120 | 0.150 | 1.9 | 2.4 | 4.75 | 6.0 | 0.110 | 0.160 |
| 315 | 355 | 0.140 | 0.170 | 2.2 | 2.7 | 5.5 | 6.75 | 0.120 | 0.180 |
| 355 | 400 | 0.150 | 0.190 | 2.4 | 3.0 | 6.0 | 7.5 | 0.130 | 0.200 |
| 400 | 450 | 0.170 | 0.210 | 2.7 | 3.3 | 6.75 | 8.25 | 0.140 | 0.220 |
| 450 | 500 | 0.190 | 0.240 | 3.0 | 3.7 | 7.5 | 9.25 | 0.160 | 0.240 |
| 500 | 560 | 0.210 | 0.270 | 3.4 | 4.3 | 8.5 | 11.0 | 0.170 | 0.270 |
| 560 | 630 | 0.230 | 0.300 | 3.7 | 4.8 | 9.25 | 12.0 | 0.200 | 0.310 |
| 630 | 710 | 0.260 | 0.330 | 4.2 | 5.3 | 10.5 | 13.0 | 0.220 | 0.330 |
| 710 | 800 | 0.280 | 0.370 | 4.5 | 5.9 | 11.5 | 15.0 | 0.240 | 0.390 |
| 800 | 900 | 0.310 | 0.410 | 5.0 | 6.6 | 12.5 | 16.5 | 0.280 | 0.430 |
| 900 | 1 000 | 0.340 | 0.460 | 5.5 | 7.4 | 14.0 | 18.5 | 0.310 | 0.470 |
| 1 000 | 1 120 | 0.370 | 0.500 | 5.9 | 8.0 | 15.0 | 20.0 | 0.360 | 0.530 |

Remarks Values for reduction in radial internal clearance are for bearings with CN clearance. For bearings with C3 Clearance, the maximum values listed should be used for the reduction in radial internal clearance.

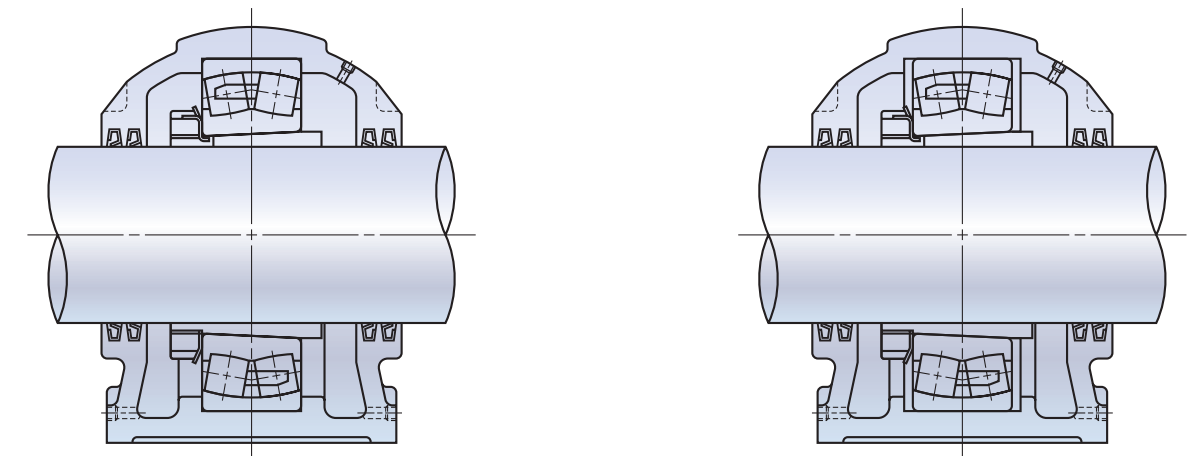

Fig. 6 Fixed-end (left) and free-end (right)

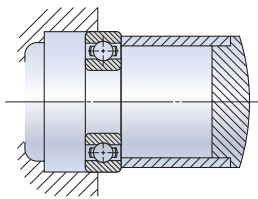

Fig. 7 Preload fitting of outer ring

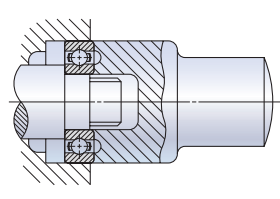

Fig. 8 Preload fitting of outer ring

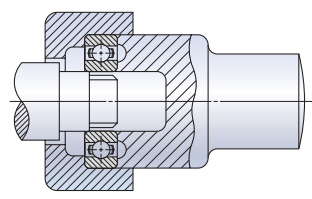

Fig. 9 Preload fitting of inner ring

2.3 Mounting with Preload Applications

2.3.1 Preload for Radial Bearings

When mounting angular contact ball bearings and tapered roller bearings, preload must be applied depending on specific usage conditions. Preload refers to the assembly adjustment in which the required load is applied in advance to the balls or rollers of a bearing while no load is applied externally (or under the conditions where rolling elements maintain their position during mounting). The purpose of preload is to minimize shaft deflection in radial or axial directions during operation within the requisite minimum allowances. Mounting with preload application is a very effective way to lessen deflection. However, under no circumstances should you ever apply a larger preload to a bearing than necessary. The amount and application method, therefore, should always be carefully observed to avoid mistakes, with due consideration for the purpose of preload.

Fig. 10 shows a situation in which two radial ball bearings' outer rings are mounted after a preload is applied to them by means of end cover screws. Although this mounting method is simple, sufficient results are not possible without careful adjustment by a skilled worker. Moreover, it is difficult to accurately measure the amount of preload using this method. Therefore, the starting frictional moment and the amount of preload of a bearing must be known in advance.

The lighter the load a bearing is required to handle during operation, the weaker the preload that would be necessary for mounting. In this connection, there is

another way in which preload may be applied to a bearing: using a spring as shown in Fig. 11. In this preloading method, the size and compression of the spring can be determined from the amount of preload. Several springs of proper size are placed at the circumference. In many cases, preloading by means of springs is conducted to lessen radial deflection. As shown in Fig. 12, applying preload to a bearing with spacers inserted into both inner and outer rings is an excellent method. This method facilitates mounting and ensures the proper application of preload. One spacer is slightly longer than another, and the dimensions of individual bearings differ slightly. For this reason, since we cannot say that similar length spacers can be applied to all bearings, the specific length must be measured and determined individually when combining bearings. Single-row angular contact ball bearings are not used independently, but always in pairs. They can be combined as front-to-front duplex bearings (DF) as shown in Fig. 13, or back-to-back duplex bearings (DB) as shown in Fig. 14.

Fig. 15 shows a situation in which no axial preload is applied, where the required deflections of inner and outer rings in the axial direction for the preload are 'a' and 'b', respectively, and preload T_1 will be obtained only after 'a' and 'b' move in an axial direction when tightened by a nut. Typically, 'a' equals 'b' for bearings of the same type. In any case, as long as 'a' and 'b' are properly designed and fabricated for the specific conditions of use, mounting can be easily carried out by simply tightening the nut firmly.

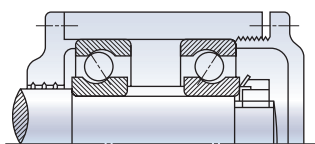

Fig. 10 Preload application by screw

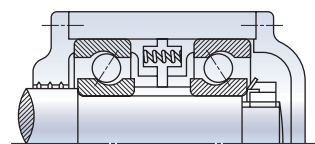

Fig. 11 Preload application by spring

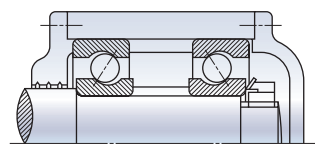

Fig. 12 Preload application by spacer (on free-end)

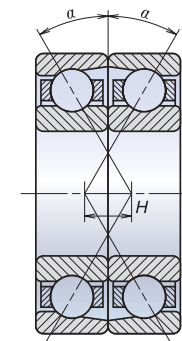

Fig. 13 Front-to-front duplex bearings

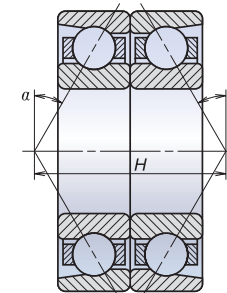

Fig. 14 Back-to-back duplex bearings

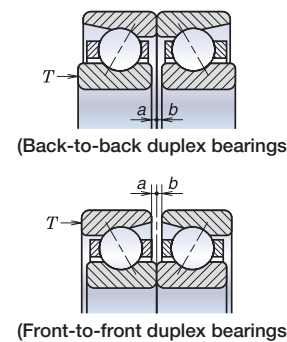

Fig. 15 Amount of preload

The relation between axial load and displacement in the axial direction of single-row angular contact ball bearings can be approximately expressed by equation (7) below.

$$\delta_a = \frac{4.4 \times 10^{-4}}{\sin \alpha} \left(\frac{Q^2}{D_a} \right)^{\frac{1}{3}} \dots \dots \dots (7)$$

Where

δ_a : Displacement in axial direction (mm)

Q : Load applied to a single ball (N)

α : Contact angle

D_a : Diameter of ball (mm)

If the axial load to be applied to the entire bearing is T , then load Q , which is applied to a single ball when the number of balls of the bearings is Z , can be expressed by the following equation (8):

$$Q = \frac{T}{Z \sin \alpha} \dots \dots \dots (8)$$

Therefore, deflection in axial direction, δ_a , can be generally expressed by the following equation:

$$\delta_a = C_a \cdot T^{\frac{2}{3}} \dots \dots \dots (9)$$

C_a is a constant determined by the individual type and dimension of the bearing.

In Fig. 16, clearances, a and b, between the bearings can be expressed by axial deflection (δ_a). And, as preload increases, clearances a and b will decrease, and the preload will become T_1 after the clearances reach zero. If the axial load, T , is applied externally to bearing A, A will further deflect by δ_i in the axial direction. Deflection of bearing B will also decrease by the same amount. Then the deflections of bearings A and B will become as follows:

$$\delta_{aA} = \delta_a + \delta_i, \delta_{aB} = \delta_a - \delta_i$$

To be more specific, the force, including preload, applied to bearing A is $(T_1 + T - G)$, and $(T_1 - G)$ is applied to bearing B.

If only δ_T deflects under axial load T when no preload is applied to a bearing, the resulting decrease in deflection of the bearing from the preload can be expressed as $(\delta_T - \delta_i)$.

Also, in the case of $G = T_1$ or $\delta_i = \delta_a$, bearing B is under no-load conditions, and the deflection of bearing A, δ_{aA} , becomes as follows:

$$\delta_{aA} = 2\delta_a = 2C_a \cdot T_1^{\frac{2}{3}} = C_a (2^{\frac{3}{2}} T_1)^{\frac{2}{3}} \dots \dots (10)$$

Moreover, the force applied to bearing A is equal to $G=T_1$, the following equation holds:

$$T_1 + (T - G) = G + (T - G) = T \dots \dots \dots (11)$$

Then, from the equations, (9), (10) and (11), the following equation holds:

$$\delta_{aA} = C_a \cdot T^{\frac{2}{3}} = C_a (2^{\frac{3}{2}} T_1)^{\frac{2}{3}} \dots \dots \dots (12)$$

That is,

$$T = 2\sqrt{2} \cdot T_1$$

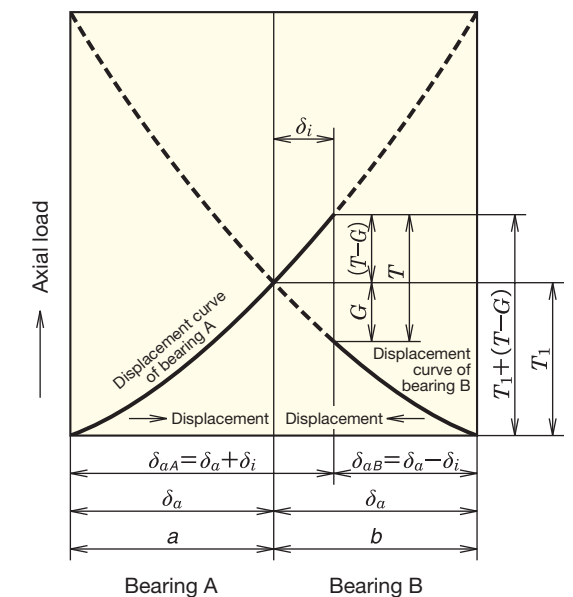

Fig. 16 Axial displacement with preload

When preload is provided, bearing A needs a load capacity that withstands axial load ($T_1 + T - G$) relative to the required life and speed conditions.

2.3.2 Preload for Thrust Bearings

Care should be taken not to allow balls or bearing rings of bearings to get out of position when the thrust ball bearings are mounted on horizontal shafts. This is especially important for double-direction thrust ball bearings or two single-direction thrust ball bearings on horizontal shafts.

In other words, if the balls on the side where no load is applied, and cages and/or bearing rings are displaced downward or off center, and load is applied to the row of bearings, damage or failure caused by heat generation will inevitably occur. For this reason, preload in the axial direction is required as a preventive measure. This misalignment of the balls and cages or bearing rings causes an uneven application of load on the balls, which leads to slippage in their motion to return to the home position, which in turn results in heat generation and damage.

As in the case of radial bearings, the preloading method can be applied by a screw or adjustment plate by which axial adjustment is made, or by a spring. Figs. 17 and 18 show some examples of these applications. However, as the former method requires difficult adjustment and requires experience, the latter method, using a spring, is

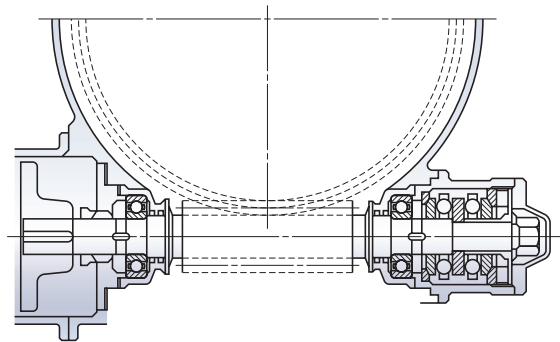

Fig. 17 Preload of thrust ball bearings (by screw)

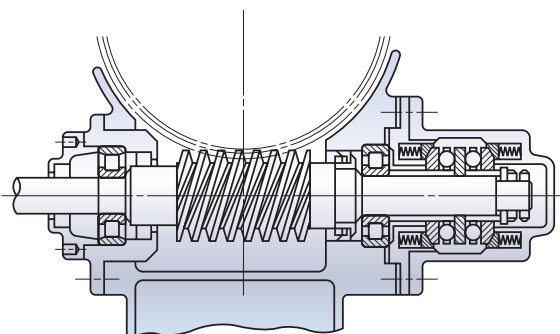

Fig. 18 Preload of thrust ball bearings (by spring)

easier and may provide better results. This preloading method can apply not only to thrust ball bearings, but also to thrust roller bearings, as shown in Fig. 19.

When the balls in thrust ball bearings rotate at relatively high speeds, sliding due to gyroscopic moments on the balls may occur. The larger of the two values obtained from equations (13) and (14) below should be adopted as the minimum axial load in order to prevent such sliding.

$$F_{a \min} = \frac{C_{0a}}{100} \left(\frac{n}{N_{\max}} \right)^2 \dots \dots \dots (13)$$

$$F_{a \min} = \frac{C_{0a}}{1000} \dots \dots \dots (14)$$

Where

- $F_{a \min}$: Minimum axial load (N)
- C_{0a} : Basic static load rating (N)
- n : Speed (min^{-1})
- N_{\max} : Limiting speed (oil lubrication) (min^{-1})

When spherical thrust roller bearings are used, damage such as scoring may occur due to sliding between the rollers and outer ring raceway while in use. The minimum axial load $F_{a \min}$ necessary to prevent such sliding is obtained from the following equation:

$$F_{a \min} = \frac{C_{0a}}{1000} \dots \dots \dots (15)$$

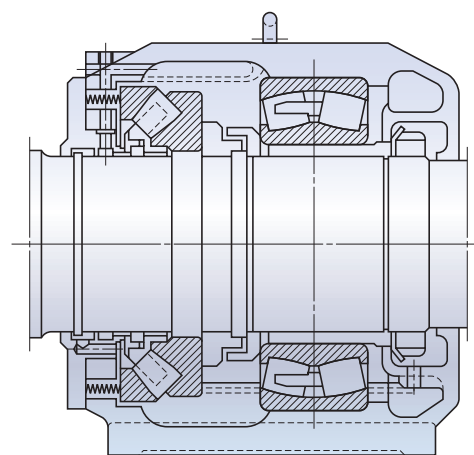

Fig. 19 Preload of thrust roller bearings (by spring)

2.4 General Mounting Precautions

To fix a radial bearing to a shaft, generally bring the bearing into close contact with the shaft shoulders and spacer and fix it in position by tightening the shaft nut. The ends of the shaft shoulders and the spacer must be perpendicular to the shaft center line. If the components are not perpendicular, bearing rotation accuracy and roller contact performance will be adversely affected, resulting in heat generation and premature fatigue. The same care must be taken to ensure the proper contact between the housing shoulders and the lateral face of the outer rings.

Since shaft shoulder height and the outer diameters of spacers or the housing shoulder height are closely related to the dismounting of bearings, their standard dimensions are described in the JIS as well as in our catalogues for reference purposes. Along with these shoulder heights, the fillet radius in the corners of shafts and housings is also important. Table 6 shows the values of these shoulder heights and fillet radii in the corners. The spherical washers of thrust ball bearings are usually mounted in place, with a clearance between the washers and the housing, except for the highly accurate main shafts of machine tools. For thrust ball bearings with flat seats, in particular, perpendicularity between shafts and housing shoulders must be achieved with a high degree of accuracy, in the same way as described previously. Mounting should be done with utmost attention to eccentricity as well.

Although bearings with greater accuracy may be required for ensuring the overall accuracy of a machine, the accuracy of shafts, housings, and other related components should also be improved in conformity with bearing accuracy; inaccuracy of related components is a leading cause of bearing damage.

Furthermore, as a general precaution to ensure proper mounting, it is important to keep bearings and related components as clean as possible. This means they should be handled in an environment free from debris or high humidity, using clean rinsing oil, with due consideration for guarding against corrosion or rust. Be sure to check each part before mounting. Inspect the sealed areas as well as dimensions, shape, appearance and accuracy of shafts and housings. While checking, use care to prevent perspiration from the hands, or debris present at the site, from coming into contact with the bearings.

Fitting work for bearings and clearance measurement methods have already been discussed. Ideally, plan carefully before proceeding to mounting procedures, and always maintain a well-documented record of each operation.

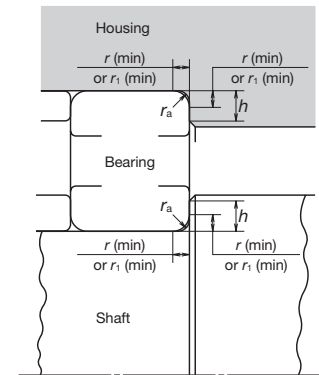

Fig. 20 Chamfer dimensions, fillet radius of shaft and housing, and shoulder height

Table 6 Recommended minimum shoulder heights and fillet radius of shaft and housing for use with metric radial bearings Units: mm

| Nominal Chamfer Dimensions | Shaft or Housing | | |
|----------------------------|------------------------------|---|---|
| | Fillet Radius r_a (max) | Minimum Shoulder Heights h (min) | |
| r (min) or r_1 (min) | | Deep Groove Ball Bearings (1), Self-Aligning Ball Bearings, Cylindrical Roller Bearings (1), Solid Needle Roller Bearings | Angular Contact Ball Bearings, Tapered Roller Bearings (2), Spherical Roller Bearings |
| 0.05 | 0.05 | 0.2 | — |
| 0.08 | 0.08 | 0.3 | — |
| 0.1 | 0.1 | 0.4 | — |
| 0.15 | 0.15 | 0.6 | — |
| 0.2 | 0.2 | 0.8 | — |
| 0.3 | 0.3 | 1 | 1.25 |
| 0.6 | 0.6 | 2 | 2.5 |
| 1 | 1 | 2.5 | 3 |
| 1.1 | 1 | 3.25 | 3.5 |
| 1.5 | 1.5 | 4 | 4.5 |
| 2 | 2 | 4.5 | 5 |
| 2.1 | 2 | 5.5 | 6 |
| 2.5 | 2 | — | 6 |
| 3 | 2.5 | 6.5 | 7 |
| 4 | 3 | 8 | 9 |
| 5 | 4 | 10 | 11 |
| 6 | 5 | 13 | 14 |
| 7.5 | 6 | 16 | 18 |
| 9.5 | 8 | 20 | 22 |
| 12 | 10 | 24 | 27 |
| 15 | 12 | 29 | 32 |
| 19 | 15 | 38 | 42 |

Notes (1) When heavy axial loads are applied, the shoulder greater must be sufficiently higher than the values listed.

(2) For bearings with axial loads, the shoulder height must be sufficiently greater than the values listed.

Remarks 1. The fillet radius of the corner is also applicable to thrust bearings.

2. The shoulder diameter is listed instead of shoulder height in the bearing tables.

2.5 Lubrication

The lubricating methods for rolling bearings are roughly classified into oil and grease applications. Grease lubrication is the preferred method for rolling bearings, since it allows a simpler structure for bearing seals and is convenient. This method has recently become more widely used because of improvements and

development in the grease itself. Nevertheless, special attention must be paid to rotating speed, operating temperature, grease quantity, grease life, etc. Grease lubrication becomes more difficult as the rotating speed of bearings increases. The upper limit of revolution speed varies according to bearing type, dimensions,

Table 7 Brands of Lubricating Greases and Comparison of Properties

| Brands | Thickeners | Base Oils | Dropping Point (°C) | Consistency | Working Temperature Range (°C) | Pressure Resistance | Usable Limit Compared to Listed Limiting Speed (%) |
|----------------------------|------------------------|--|---------------------|-------------|--------------------------------|---------------------|--|
| ADREX | Lithium | Mineral oil | 198 | 300 | 0~+110 | Good | 70 |
| APPOLOIL AUTOREX A | Lithium | Mineral oil | 198 | 280 | -10~+110 | Fair | 60 |
| Arapen RB 300 | Lithium/Calcium | Mineral oil | 177 | 294 | -10~+ 80 | Fair | 70 |
| EA2 Grease | Urea | Poly- α -olefin oil | ≥ 260 | 243 | -40~+150 | Fair | 100 |
| EA3 Grease | Urea | Poly- α -olefin oil | ≥ 260 | 230 | -40~+150 | Fair | 100 |
| EA5 Grease | Urea | Poly- α -olefin oil | ≥ 260 | 251 | -40~+160 | Good | 60 |
| EA7 Grease | Urea | Poly- α -olefin oil | ≥ 260 | 243 | -40~+160 | Fair | 100 |
| ENC Grease | Urea | Polyol ester oil + Mineral oil | ≥ 260 | 262 | -40~+160 | Fair | 70 |
| ENS Grease | Urea | Polyol ester oil | ≥ 260 | 264 | -40~+160 | Fair | 100 |
| ECZ | Lithium + Carbon black | Poly- α -olefin oil | ≥ 260 | 243 | -10~+120 | Fair | 100 |
| ISOFLEX NBU 15 | Barium Complex | Diester oil + Mineral oil | ≥ 260 | 280 | -30~+120 | Poor | 100 |
| ISOFLEX SUPER LDS 18 | Lithium | Diester oil | 195 | 280 | -50~+110 | Poor | 100 |
| ISOFLEX TOPAS NB52 | Barium Complex | Poly- α -olefin oil | ≥ 260 | 280 | -40~+130 | Poor | 90 |
| Aero Shell Grease 7 | Micro Gel | Diester oil | ≥ 260 | 288 | -55~+100 | Poor | 100 |
| SH 33 L Grease | Lithium | Silicone oil | 210 | 310 | -60~+120 | Poor | 60 |
| SH 44 M Grease | Lithium | Silicone oil | 210 | 260 | -30~+130 | Poor | 60 |
| NS HI-LUBE | Lithium | Polyol ester oil + Diester oil | 192 | 250 | -40~+130 | Fair | 100 |
| NSA | Lithium | Poly- α -olefin oil + Ester oil | 201 | 311 | -40~+130 | Fair | 70 |
| NSC Grease | Lithium | Alkyldiphenyl ether oil + Polyol ester oil | 192 | 235 | -30~+140 | Fair | 70 |
| NSK Clean Grease LG2 | Lithium | Poly- α -olefin oil + Mineral oil | 201 | 199 | -40~+130 | Poor | 100 |
| EMALUBE 8030 | Urea | Mineral oil | ≥ 260 | 280 | 0~+130 | Good | 60 |
| MA8 Grease | Urea | Alkyldiphenyl ether oil + Poly- α -olefin oil | ≥ 260 | 283 | -30~+160 | Fair | 70 |
| KRYTOX GPL-524 | PTFE | Perfluoropolyether oil | ≥ 260 | 265 | 0~+200 | Fair | 70 |
| KP1 | PTFE | Perfluoropolyether oil | ≥ 260 | 280 | -30~+200 | Fair | 60 |
| Cosmo Wide Grease WR No.3 | Sodium Terephthalamate | Polyol ester oil + Mineral oil | ≥ 230 | 227 | -40~+130 | Poor | 100 |
| G-40M | Lithium | Silicone oil | 223 | 252 | -30~+130 | Poor | 60 |
| Shell Alvania EP Grease 2 | Lithium | Mineral oil | 187 | 276 | 0~+ 80 | Good | 60 |
| Shell Alvania Grease S1 | Lithium | Mineral oil | 182 | 323 | -10~+110 | Fair | 70 |
| Shell Alvania Grease S2 | Lithium | Mineral oil | 185 | 275 | -10~+110 | Fair | 70 |
| Shell Alvania Grease S3 | Lithium | Mineral oil | 185 | 242 | -10~+110 | Fair | 70 |
| Shell Cassida Grease RLS 2 | Aluminum Complex | Poly- α -olefin oil | ≥ 260 | 280 | 0~+120 | Fair | 70 |
| SHELL SUNLIGHT Grease 2 | Lithium | Mineral oil | 200 | 274 | -10~+110 | Fair | 70 |
| WPH Grease | Urea | Poly- α -olefin oil | 259 | 240 | -40~+150 | Fair | 70 |
| DEMNUM Grease L-200 | PTFE | Perfluoropolyether oil | ≥ 260 | 280 | -30~+200 | Fair | 60 |
| NIGACE WR-S | Urea | Mixed oil | ≥ 260 | 230 | -30~+150 | Poor | 70 |
| NIGLUB RSH | Sodium Complex | Polyalkylene Glycol oil | ≥ 260 | 270 | -20~+120 | Fair | 60 |
| PYRONOC UNIVERSAL N6B | Urea | Mineral oil | 238 | 290 | 0~+130 | Fair | 70 |
| PALMAX RBG | Lithium Complex | Mineral oil | 216 | 300 | -10~+130 | Good | 70 |
| Beacon 325 | Lithium | Diester oil | 190 | 274 | -50~+100 | Poor | 100 |
| MULTEMP PS No.2 | Lithium | Mineral oil + Diester oil | 190 | 275 | -50~+110 | Poor | 100 |
| MOLYKOTE FS-3451 Grease | PTFE | Fluorosilicone oil | ≥ 260 | 285 | 0~+180 | Fair | 70 |
| UME Grease | Urea | Mineral oil | ≥ 260 | 268 | -10~+130 | Fair | 70 |
| UMM Grease 2 | Urea | Mineral oil | ≥ 260 | 267 | -10~+130 | Fair | 70 |
| RAREMAX AF-1 | Urea | Mineral oil | ≥ 260 | 300 | -10~+130 | Fair | 70 |

Notes (1) If grease will be used at the upper or lower limit of the temperature range or in a special environment such as vacuum, please consult with NSK.
 (2) For short-term operation or when cool, grease may be used at speeds exceeding the above limits provided the supply of grease is appropriate.

lubricating methods and service conditions. In the dimension table of NSK's rolling bearing catalogue, the limiting speeds are listed by bearing, assuming normal operation conditions.

The operating temperature range of grease varies depends on the type of grease used. Table 7 shows the generally recommended temperature range. When grease is used outside this temperature range, care should be used for replenishing the lubricant. Sufficient grease must be packed inside the bearing, including the cage guide face. The available space inside the housing to be packed with grease, excluding the bearing and shaft, depends on the speed, as follows:

- 1/2 to 2/3 of the space (Less than 50% of the limiting speed)
- 1/3 to 1/2 of the space (More than 50% of the limiting speed)

Since the quality and property of greases change as they are used, they must be replaced after a given period has elapsed. Serviceability limits cannot be readily determined for all applications, since changes in quality and properties are affected by operating and external conditions. Operators may also find it difficult to determine the timing of replacement based on appearance.

Assuming that the greases are used under normal operating conditions, refer to Figs. 23 and 24 on page 16 concerning replacement time intervals.

Oil lubrication is widely used. Oil features excellent flowability and heat dissipation capacity and is suitable for circulating and forced lubrication, from which debris and abrasive particles are easily removed. It also has a positive effect on vibration and acoustic properties, and therefore is the optimum choice as a lubricant. However, oil lubrication clearly adds complexity to the lubrication system and requires careful maintenance. Furthermore, bearing seals must be carefully tended to

prevent oil leakage.

Selecting the proper lubrication oil involves considering its viscosity at the operating temperature of the applicable bearing. It is generally better to choose an oil having the following viscosity or higher at the respective operating temperature for the applicable bearing types:

- Ball bearings and cylindrical roller bearings 13 mm²/S or higher
- Spherical roller bearings and tapered roller bearings 20 mm²/S or higher
- Spherical thrust roller bearings 32 mm²/S or higher

Fig. 22 shows the general relationship between oil viscosity and temperature, although some variations from these numbers can be found.

Lubricating methods include oil bath lubrication, splash lubrication, forced circulating lubrication, and oil mist lubrication. The selection of the proper lubricating methods depends on the structures in the vicinity of the bearings and operating conditions. The most typical limiting speeds for bearings adopting oil bath lubrication are also listed in our catalog's dimension table.

2.6 Test Operation

A test operation should be performed after mounting has been completed. Items to be checked during the test include the existence of abnormal noise and excessive rise in bearing temperature. Needless to say, bearing rotation must be smooth during test operation. If any abnormality is found during the test operation, immediately discontinue the test, dismount the bearing and conduct an inspection depending on the specific abnormality.

Especially for high-speed machines, start the operation

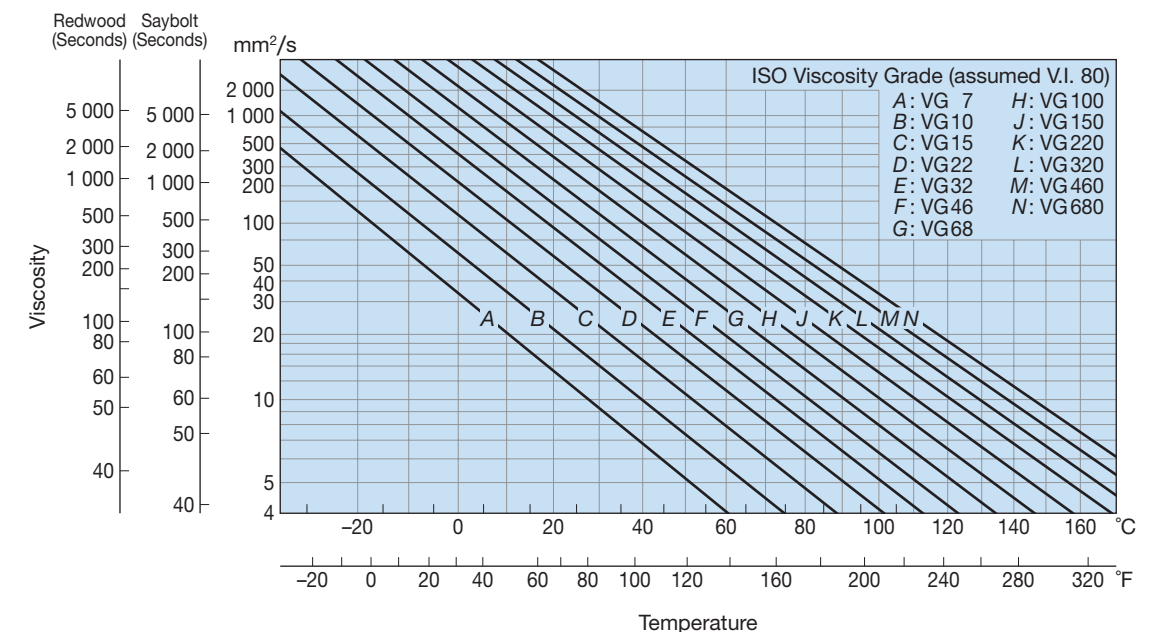

Fig. 22 Temperature-Viscosity chart

at lower speeds, then gradually increase speed. Although bearing temperature can generally be estimated by the temperature of the outside surface of the housing, it is better to directly measure the temperature of the outer ring using oil holes for access. Changes in temperature can also be estimated by the temperature of the lubricant. Since, in general, bearing temperature gradually rises and reaches saturation temperature over time, it is possible to confirm that mounting has been done correctly by monitoring the rise in temperature. In the event of problems with the bearing, its mounting, or both, bearing temperature may not level off but will increase to an abnormal level.

The saturation temperature of a bearing varies depending on heat capacity, heat release, number of revolutions and load of the host machine. Usually the rise in temperature will range from 20°C to 30°C.

The probable causes of unrestrained temperature rise to abnormal levels are:

- Excessive supply of grease or oil
- Excessive friction of the bearing seals
- Insufficient bearing clearance

- Excessive speed with respect to bearing type and lubricating method
- Abnormal load on bearing
- Improper contact of bearing due to inaccurate shaft, housing, or shoulders
- Defective bearings, etc.

Moreover, there may be cases involving improper mounting, inaccurate fabrication, or the incorrect selection of a bearing.

The sound of a bearing may be checked with a noise locator or other listening instrument placed in contact with the housing. Abnormal conditions, such as a loud metallic sounds, strange noises or other irregular sounds, may be caused by insufficient lubricant, inaccurate shaft or housing, the entry of foreign particles or debris into the bearing, or defective bearings.

For reference purposes, probable causes of various types of bearing failure and related countermeasures are shown in Table 8.

The results of the test operation must always be recorded for reference after mounting has been completed, as a future reference for troubleshooting.

Table 8 Causes of and Countermeasures for Operating Irregularities

| Irregularities | | Possible Causes | Countermeasures |
|---------------------------------------|---|--|---|
| Noise | Loud Metallic Sound (°) | Abnormal Load | Improve the fit, internal clearance, preload, position of housing shoulder, etc. |
| | | Incorrect mounting | Improve the machining accuracy and alignment of shaft and housing, accuracy of mounting method. |
| | | Insufficient or improper lubricant | Replenish the lubricant or select another lubricant. |
| | | Contact of rotating parts | Modify the labyrinth seal, etc. |
| | Loud Regular Sound | Flaws, corrosion, or scratches on raceways | Replace or clean the bearing, improve the seals, and use clean lubricant. |
| | | Brinelling | Replace the bearing and use care when handling bearings. |
| | | Flaking on raceway | Replace the bearing. |
| | Irregular Sound | Excessive clearance | Improve the fit, clearance and preload. |
| | | Penetration of foreign particles | Replace or clean the bearing, improve the seals, and use clean lubricant. |
| Flaws or flaking on balls | | Replace the bearing. | |
| Abnormal Temperature Rise | Excessive amount of lubricant | Reduce amount of lubricant, select stiffer grease. | |
| | Insufficient or improper lubricant | Replenish lubricant or select a better one. | |
| | Abnormal load | Improve the fit, internal clearance, preload, position of housing shoulder. | |
| | Incorrect mounting | Improve the machining accuracy and alignment of shaft and housing, accuracy of mounting, or mounting method. | |
| | Creep on fitted surface, excessive seal friction | Correct the seals, replace the bearing, correct the fitting or mounting. | |
| Vibration (Axial runout) | Brinelling | Replace the bearing and use care when handling bearings. | |
| | Flaking | Replace the bearing. | |
| | Incorrect mounting | Correct the squareness between the shaft and housing shoulder or side of spacer. | |
| | Penetration of foreign particles | Replace or clean the bearing, improve the seals. | |
| Leakage or Discoloration of Lubricant | Too much lubricant. Penetration by foreign matter or abrasion chips | Reduce the amount of lubricant, select a stiffer grease. Replace the bearing or lubricant. Clean the housing and adjacent parts. | |

Note (°) Squeaking may be heard in medium- to large-sized cylindrical roller bearings or ball bearings that are operating under grease lubrication in low-temperature environments. Under such conditions, even when squeaking occurs, the bearing temperature will not rise and fatigue or grease life will not be affected. Consequently, such a bearing can continue to be used.

3

Maintenance and Inspection

3.1 Procedures of Maintenance and Inspection

Consistent maintenance and regular inspections are required to ensure continued use of the bearing throughout its operating life so that problems are identified and resolved early to avert future (and potentially escalating) problems or accidents. Inspection of bearings during operation is integrated into such activities as occasionally listening to the sound of the bearings, monitoring bearing temperature, or investigating bearing vibration. Even a slight flaking of the bearing will create abnormal or irregular noise that can be readily distinguished from normal sound by a skilled worker using a noise locator. Although bearing temperature can be roughly determined by simply touching the housing surface, please insert a thermometer into a lubrication hole or similar point of entry to directly measure bearing temperature. Bearings for moving units that cannot be monitored for noise or temperature during operation, such as roller bearings for vehicles, should be periodically inspected, and fresh grease should be applied. Examining the condition of the grease during operation is also a useful method for determining the operational condition of the bearing. The operational condition can be determined by the amount of dirt and fine iron powder contained in the grease as well as any sign of leakage or deterioration of the grease. Whenever such inspections reveal abnormality or failure of the bearing, the bearing should be disassembled for further detailed inspection to identify the cause.

3.2 Lubrication Method

3.2.1 Grease Lubrication

Lubricant is indispensable for bearings; however, only a small amount of lubricant is required and typically does not need to be replenished often. The interval varies depending on bearing type, dimension, number of revolutions and other operational conditions. These factors can often be determined empirically. Figs. 23 and 24 summarize the guidelines for the grease replenishment interval under normal operational conditions, represented by the operation hours t_r , which is applicable to a bearing load on the order of 1/10 of the basic dynamic load rating or less and at a bearing temperature no greater than 70°C. The lubricating performance of grease deteriorates because of emulsification or deterioration caused by the entry of foreign matter or moisture. Therefore, the lubrication interval should be shortened to 1/2–1/10 of the values obtained from Figs. 23 and 24 in the event a bearing is operated in environments exposed to significant levels of dust or vibration. A housing should be designed in consideration of the need to replenish or replace the grease. For example, a housing used for machines requiring occasional replacement of grease should be easy to disassemble, and, since grease will be frequently replenished in situations in which the entry of water through a sealing device cannot be avoided, the housing must be designed so that the old grease can be readily discharged. Although the housing may be filled with grease when the bearing is used for extremely low-speed operation, avoid complete filling with grease in high-speed applications.

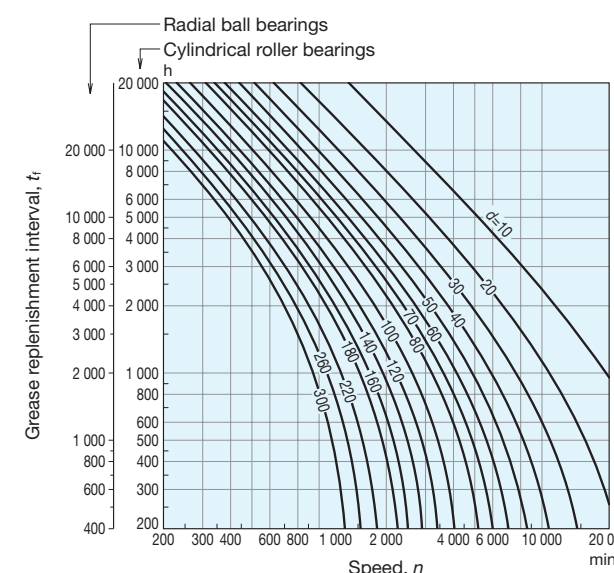

Fig. 23 Grease Replenishment Intervals for Radial Ball Bearings, Cylindrical Roller Bearings

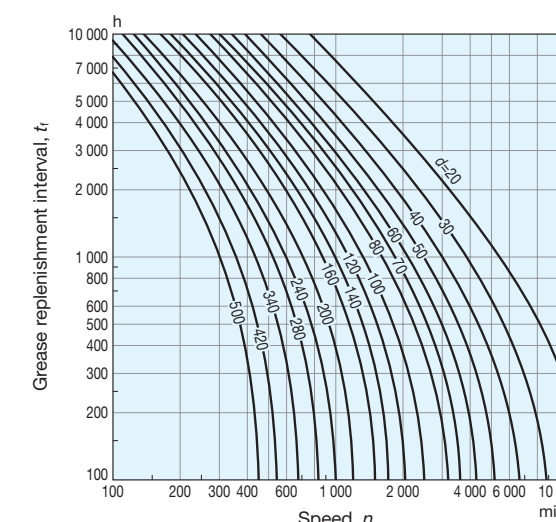

Fig. 24 Grease Replenishment Intervals for Tapered Roller Bearings, Spherical Roller Bearings

When a housing can be regularly disassembled, it is better not to drill a grease supply hole. In practical terms, grease will only reach the periphery of the supply hole without reaching the bearing, and thus may actually impair performance.

However, larger bearings or bearings used for higher-speed operations require frequent, proper greasing. In this case, a grease supply hole should be drilled since it is difficult to disassemble the housing at every greasing. It is recommended to partition the housing space on the side of the supply hole into several grease sectors (Fig. 25) in order to infuse new grease into the bearing without filling up the housing. A wide housing space should be provided at the opposite side of the supply hole in order to collect old grease, which should be occasionally discharged by opening the cover.

Bearings used for high-speed operation can be greased more easily using a grease valve. This is appropriate for bearings used for long-term continuous operations, such as electric motors or turbine pumps. The grease valve is intended to obviate grease depletion. Fig. 26 illustrates the location of grease sectors and the provision of a grease valve with a housing.

Fig. 27 shows a plumber block provided with a grease valve, where a thin iron plate *b* partitions grease sectors.

3.2.2 Oil Lubrication

An oil gauge, provided with a bath lubrication housing, should be read when the bearing is not in use in order to determine the oil level and lessen the chance of error occurring. In principle, if the quantity of oil is less than the proper oil level, oil should be supplied; however, if the sealing device is functioning properly with no hydraulic leakage, there is less need for lubrication replenishment. The need for oil replacement depends on operating conditions. If a bearing is used at a temperature of 50 °C or lower in a favorable environment with little dust or dirt, an oil change intervals up to one year should be sufficient.

If the bearing is used at an operating temperature exceeding 100 °C with an external heat source, the oil should be replaced every two or three months or more frequently, even if the used oil is thermally stable. In case of drop lubrication, the number of drops should be appropriately adjusted according to the specific conditions; however, several drops per minute should be sufficient under normal conditions. In case of high-speed operation, where the bearing is lubricated by oil-jet lubrication, the lubricant quantity will be adjusted by the oil pressure and the nozzle bore diameter. It is important to ensure that the supplied oil will not accumulate at the bearing section.

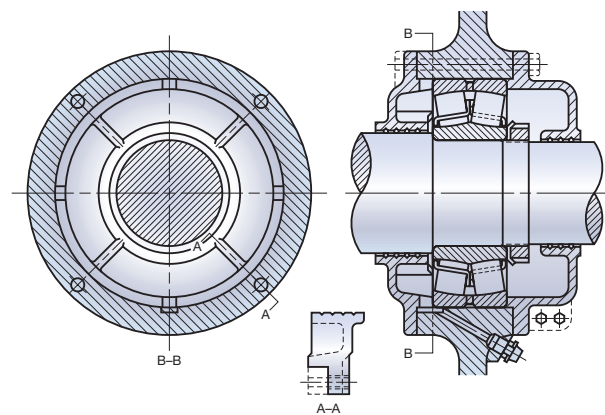

Fig. 25 Grease sectors

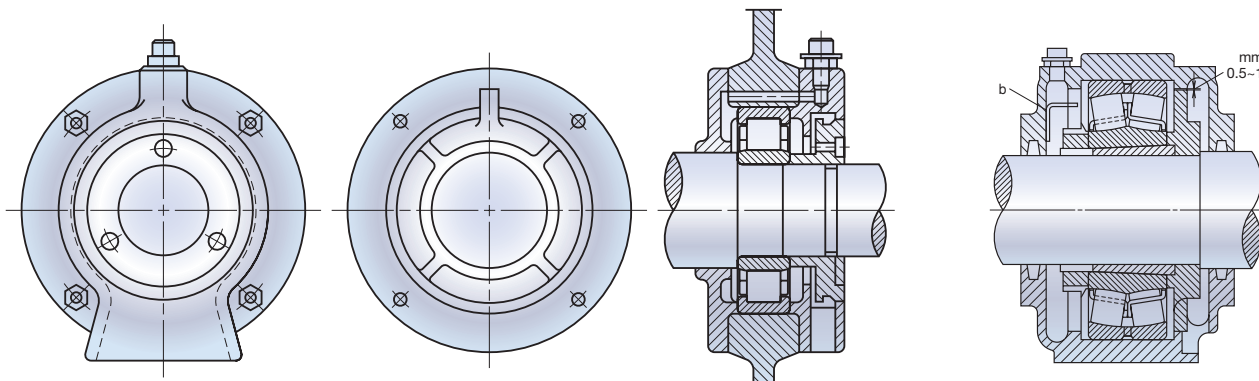

Fig. 26 Grease valve

Fig. 27 Grease valve (plumber block)

3.3 Bearing Failure

Carefully observing a bearing that failed prematurely and inspecting the lubrication conditions and the mounting conditions to investigate the process leading to failure of the bearing is important to prevent recurrence. Likely causes include improper mounting, handling or lubrication; incomplete sealing structure; and insufficient consideration for thermal effect. For instance, rib scoring, one example of premature failure, may be the result of shortage of oil, faulty lubrication system, use of improper lubricant, entry of water or foreign matter, excessive relative tilt angle between the inner ring and the outer ring due to excessive mounting error or excessive deflection of the shaft, or any combination of these. Thus, it is too difficult to find the real cause by only inspecting the failed bearing itself. However, by tracing down the conditions before and after the occurrence of

Running Traces and Applied Loads

As the bearing rotates, the raceways of the inner ring and the outer ring make contact with the rolling elements. This results in a wear path on both the rolling elements and raceways. It is normal for the running trace to be marked on the raceway, and the extent and shape of this running trace provides a useful indication of loading conditions.

It is possible to determine from careful observation of the running traces whether the bearing is carrying a radial load, a large axial load, or a moment load, or if there is extreme rigidity variations of the housing. Unexpected load applied on the bearing or excessive mounting error or the like can also be determined, providing a clue to the investigation of

failure, and after checking the machine and the area which the bearing was applied, and also the operating conditions and handling/operating histories, it becomes possible to determine several probable causes. This will help prevent recurrence of bearing failure. The quickest way to identify the cause is to painstakingly note all aspects of the failed bearing, including contact corrosion or flaws on the inner diameter surface and the outer diameter surface, as well as the condition of the bearing interior, such as the running track on the raceway and the sliding area, including the rib. At the same time, studying undamaged bearings used under similar operating conditions is often useful. To sum up, comprehensive examination of the machinery using the bearing is important. Representative cases of bearing failure are provided below for your reference.

causes for bearing failure. Representative running traces of deep groove ball bearings are shown in Fig. 28.

Fig. 28 (a) to (d), show general running traces under radial load or axial load. The running traces vary according to whether the load is fixed to the inner ring or the outer ring, and according to load conditions. Fig. 28 (e) shows running traces with a shaft inclined due to misalignment; (f) is a running trace under a moment load; (g) is a running trace in a housing which is elliptically shaped and has poor inner diameter accuracy; and (h) is a running trace in a bearing with insufficient internal clearance. Running traces (e) to (h) often cause bearing failure, and must be carefully observed.

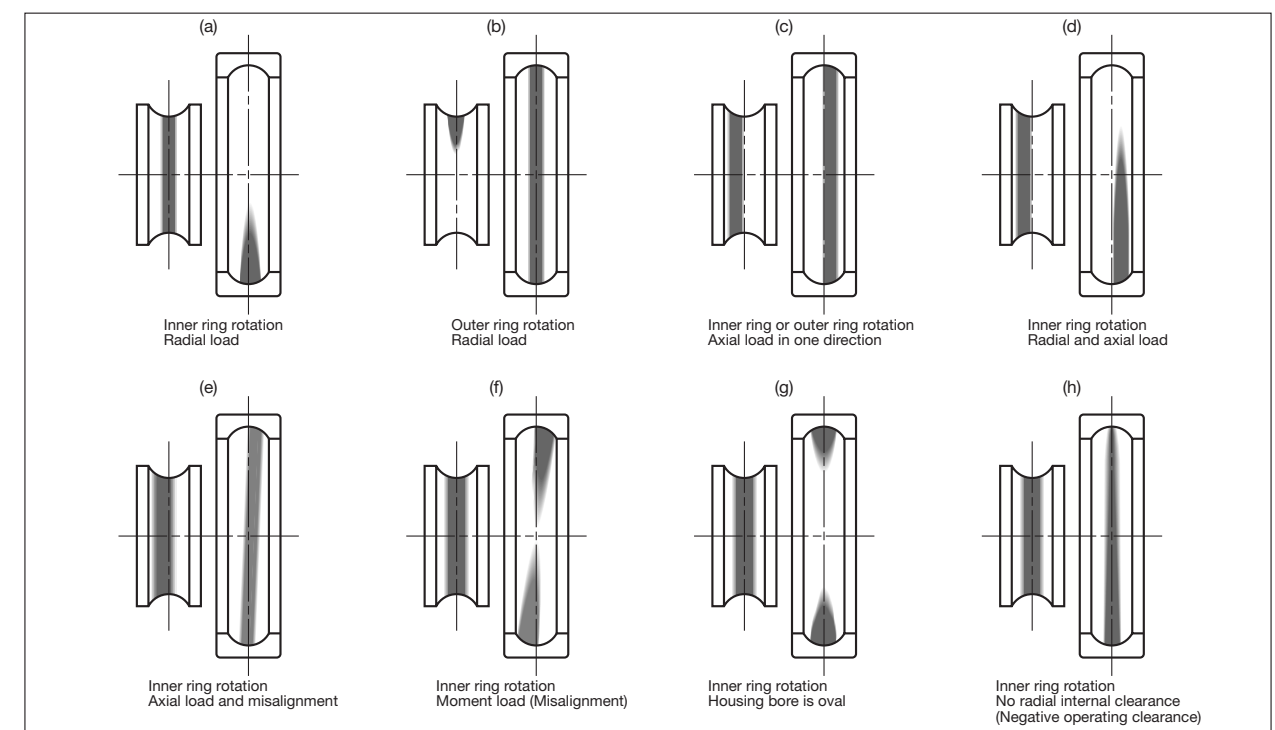

Fig. 28 Typical Running Traces of Deep Groove Ball Bearings

● Flaking

Although flaking on a bearing appears to an extremely small extent at first, it will extend significantly in a relatively short time (Fig. 29). It cannot be easily determined whether the flaking can be attributed to bearing life, where flaking appears in the course of normal operation, or as a result of abnormal load. In addition, unlike other failures, flaking is often caused by the complicated interplay of lubrication, load and vibration factors, and thus, it is difficult to narrow down to a single cause. However, since the probability of premature cracks is extremely low where the bearing is used under proper lubrication and load, lubrication and the scale of load should be investigated as possible sources of trouble. Fig. 30 shows early-stage flaking that occurred only on one side of a spherical roller bearing as a result of an excessive axial load. In addition to such abnormal load, causes of early-stage flaking include mounting in a tilted position, improper selection of bearing clearance, and poor accuracy of housing.



Fig. 29 Flaking



Fig. 30 Flaking

● Fracture and Cracks

Fig. 31 shows fracture on the large rib of the inner ring of a tapered roller bearing. This occurs when an abnormal axial load or a shock load is applied to a bearing or when an abnormal force is applied to the rib when mounting or dismounting the bearing. Causes of cracks include application of a heavy shock load (Fig. 32) and excessive interference. Where the bearing is supported only by the two edges of the outer ring, it may break along the axial plane and where there is slippage between the inner outer ring and the shaft or housing, a crack will occur at right angles to the direction of slippage. This phenomenon is seen in cases where the outer ring is loosely fit with the shaft and creeping occurs.

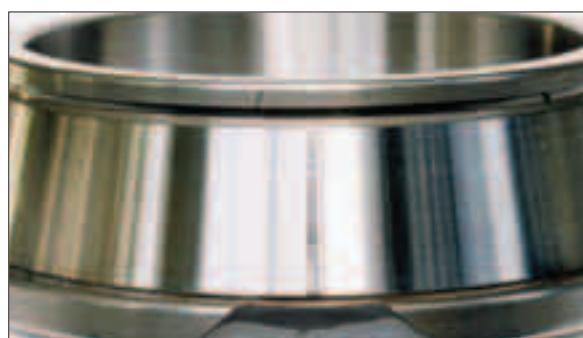

Fig. 31 Fracture



Fig. 32 Crack

● Denting

Raceway dents (Brinell dents) can occur as a result of careless handling of the bearing, catching particles, or a heavy shock load applied to the bearing at rest. In addition, a dent similar to a Brinell dent may be caused by advanced abrasion in the contact area between the rolling element and the raceway resulting from vibration or oscillatory motion. This phenomenon, known as false brinelling, is often seen, especially in cases where a bearing is transported while mounted in a machine (Fig. 33).

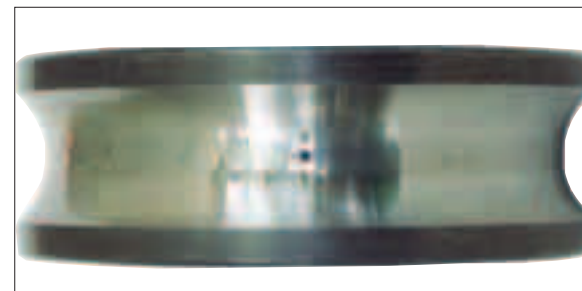

Fig. 33 Denting

● Scoring

In a roller bearing, a failure occurs on the rib surface or the roller end resulting from accumulated small seizures caused by insufficient lubricant or debris catching on the rib surface or the roller end, prior to seizures occurring on the rolling surface (Fig. 34) (Fig. 35). Therefore, damage occurs on the rib surface or roller end before it appears on the rolling surface.

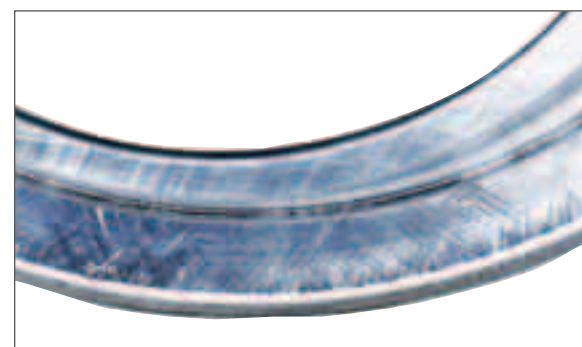

Fig. 34 Scoring on the Rib of Spherical Roller Bearing



Fig. 35 Scoring on the Roller End Face

● Wear

Factors influencing wear include entry of debris, insufficient lubricant and improper lubricant (Fig. 36), or where entry of water causes corrosive wear on the sliding surface or on the rolling surface. In addition, abrasion may be caused on the fitted shaft surface by creep resulting from inappropriate fitting.

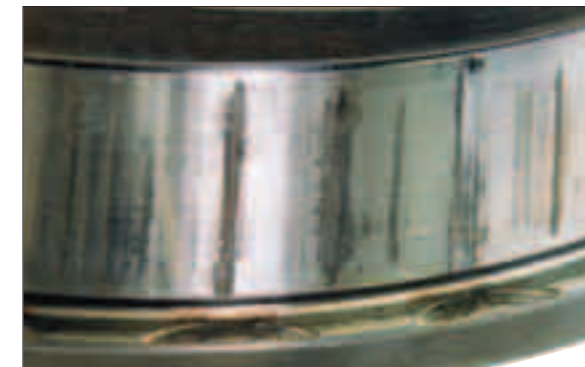

Fig. 36 Wear

● Rust

Rust in the bearing interior is caused by the entry of moisture or improper lubricant. Fig. 37 shows an example of rust caused by poor lubrication due to the entry of moisture. Reddish brown or black abrasive powder may appear on the fitted shaft surface between the shaft/housing and inner ring/outer ring. The oxide is generated by oxidation of the fitted shaft surface resulting from the slight sliding between the shaft/housing and inner ring/outer ring that occurs when contact between them is poor and is often seen in areas where vibration or heavy loads have been applied. This phenomenon, known as fretting (also called fretting corrosion), is similar to rust at first glance.



Fig. 37 Rust

● Electrical Corrosion

When electric current passes through a bearing in operation, the contact area between the inner/outer ring and the ball/roller will locally melt due to electric arcing through the extremely thin oil film to form groove-like corrugations. In a conspicuous case, these grooves may appear as a pitted surface or a striped uneven surface. (Fig. 38). When the extent of the electric corrosion is significant, flaking will be induced or the hardness of the raceway surface will be impaired resulting in advanced abrasion.



Fig. 38 Electric Corrosion

● Smearing

Smearing is surface damage which occurs between the raceway surface and the rolling surface caused during operation by a collection of small seizures resulting from sliding and oil film rupture. The failure surface becomes rough as a result of the accumulation of minute adhesions as shown in Fig. 39. Improved lubricant and lubrication method are required.



Fig. 39 Smearing

● Creep

Creep is a phenomenon in bearings where relative slipping occurs at the fitting surfaces (between the bore surface of inner ring and the shaft; and between the outside surface of outer ring and the housing), and thereby creates a clearance at the fitting. A creeping fitting surface causes a shiny or smoky surface, with the occasional appearance of scoring or wear. Fig. 40 shows an example of this failure. Checking the interference of fitting surfaces and lateral tightening of the outer ring are effective in preventing creep. Lubrication between the bearing and the shaft/housing is effective for preventing scoring or wear.



Fig. 40 Creep

4 Dismounting

Bearings are dismantled for periodic inspection or replacement. If the removed bearing is to be reused or it is removed only for inspection, dismantling needs to be conducted as carefully as mounting, taking care not to damage the bearing or individual components. Since it is particularly difficult to dismount bearings that are tightly fitted, sufficient consideration should be given at the design stage to the structure surrounding the bearing so that the bearing can be easily dismantled. It is also important to design and manufacture dismantling tools as required.

All possible preparations must be made for dismantling bearings by studying the dismantling method, the sequence of procedures, and the fitting conditions of the bearing as displayed in drawings.

When investigating the cause of bearing failure, the bearing also needs to be treated carefully, as described above, to preserve the condition of the bearing prior to dismantling. In the course of dismantling a bearing, take care not to scratch the bearing, wipe off any grease, or remove dust, dirt or iron powder, since these actions may prevent identifying the cause of the failure.

Although a loosely fitted bearing can be easily dismantled, exercise extreme care when the bearing is tightly fixed.

4.1 Dismounting Outer Rings

Fig. 41 shows an easy, effective method for dismantling a bearing with a tightly fitted outer ring. In this method, dismantling bolts are first placed into push-out holes at

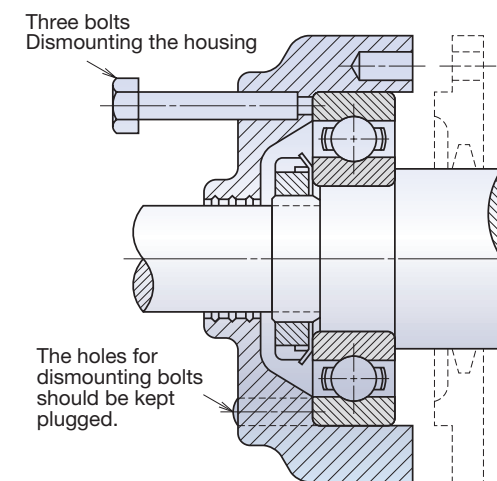

Fig. 41 Dismounting the Outer Ring

three points in the housing that are plugged except when dismantling the bearing.

The method shown in Fig. 42 is recommended for housings with back and front covers fitted by through bolts. The inner ring/outer ring grooves must be protected from dents or scratches as the bearing is pulled out using a special nut that simultaneously supports both the inner and outer rings of the bearing. Depending on circumstances, the bearing may be dismantled by heating the housing; however, the circumference must be uniformly heated or the housing may be contorted or cracked. Also note that if the housing is heated for too long, the bearing may expand and become difficult to pull out.

4.2 Dismounting Inner Rings

Dismounting an inner ring is more difficult than mounting the ring when it is tightly fitted. Although a claw tool is often used to hook and then dismount an inner ring, using the same tool to pull out an outer ring may dent the raceway or spoil the bearing.

An easy method, which is often used when the inserted interference is relatively small (Fig. 43-a), involves making two or three notches on the shaft shoulder and then tapping with a hammer and patch to pull out the inner ring. However, the blow can be more safely applied using a doubled ring as shown in Fig. 43-b, since there is a risk of tapping so hard that the patch may slip and allow the small rib of the inner ring to be damaged.

Other safer methods include using a tube as an

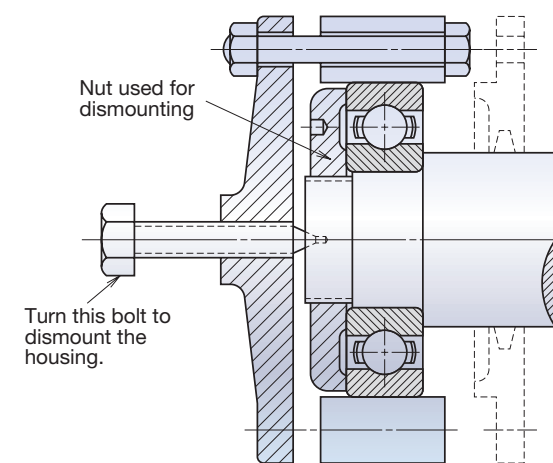

Fig. 42 Dismounting the Outer Ring

intermediary as shown in Fig. 43-c. Using a screw or a press is also recommended.

The tool shown in Fig. 44 is also effective for withdrawing an inner ring. Back plate A, consisting of an upper board and a lower board, is fastened with bolts. Inserting a steel ball (thrust ball bearing for a large-size bearing) between front plate B and bolt C increases reliability. Appropriate bolt holes should be drilled in A and B according to the size of the individual bearing. The force required for pulling out the inner ring can be obtained using the aforementioned equation (5) and Tables 3 and 4. The back cover of the housing may be used instead of back plate A, depending on specific conditions. Large-size roller bearings with large interference can be dismantled more easily without damaging the inner ring, in accordance with the previously described mounting/dismounting method by induction heating. When this device is not available, the inner ring may be expanded by heating the circumference with a burner or similar equipment. This method is intended to prevent damage to the shaft without regard for the possible reuse of the bearing.

The dismantling of bearings must be sufficiently considered well in advance, at the design stage, and the appropriate method must be selected and prepared for prior to implementation.

In other words, no aspect of bearing design is complete unless the processes of mounting and dismantling have been taken into account.

4.3 Bearing Cleaning

When bearings used for a given period of time are dismantled for inspection, they should be cleaned. First inspect the old grease coating the bearing, then clean

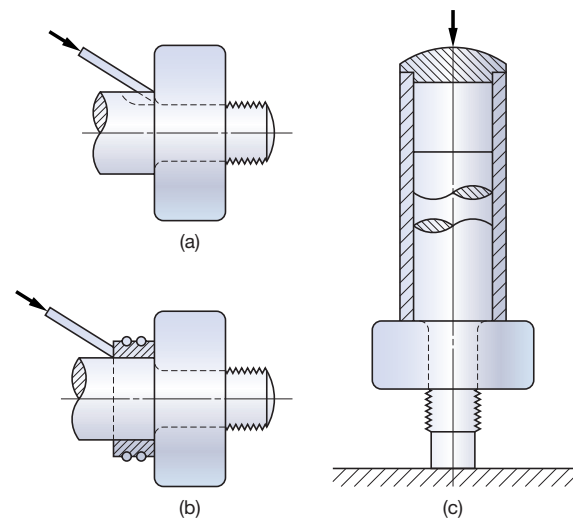

Fig. 43 Dismounting the Inner Ring

the bearing and examine its condition. Dismounted bearings should first be given a preliminary cleaning followed by a finishing rinse. During preliminary cleaning, it is better to use a brush to gently remove any grease containing dust, dirt, or abrasive powder, without rotating the bearing.

New bearings are always coated with an anti-corrosion agent prior to packaging. Generally, these bearings do not need to be cleaned only to remove the anti-corrosion agent. Since only a thin coating of anti-corrosion agent covers the surface of the bearing, there should not be any harmful effect from leaving the agent on the bearing, even when mixed with a lubricant or lubrication grease. Greater damage can be caused by cleaning the bearing in an environment exposed to contaminated oil, dust, or dirt. Nevertheless, removing the anti-corrosion agent is recommended for small bearings used in high-speed operations or for bearings that will use low-viscosity or mist lubrication.

Therefore, in principle, bearings should be cleaned when they are being examined; when dust and dirt have adhered to the bearing; or when the machine using the bearing operates at a level of speed or accuracy that would be impaired by even the slightest resistance to bearing rotation.

Kerosene is generally used as a cleaning agent. Low-viscosity spindle oil may be jet-sprayed. Compressed air is also used to remove dust and dirt from the bearing, unless the applied air contains moisture or dust/dirt; air usually contains moisture that often condenses into water droplets at the tip of the nozzle. Therefore due care must be exercised when using compressed air. In addition, since cleaning a bearing while rotating the bearing by blowing it with compressed air can damage the raceway, the inner ring/outer ring

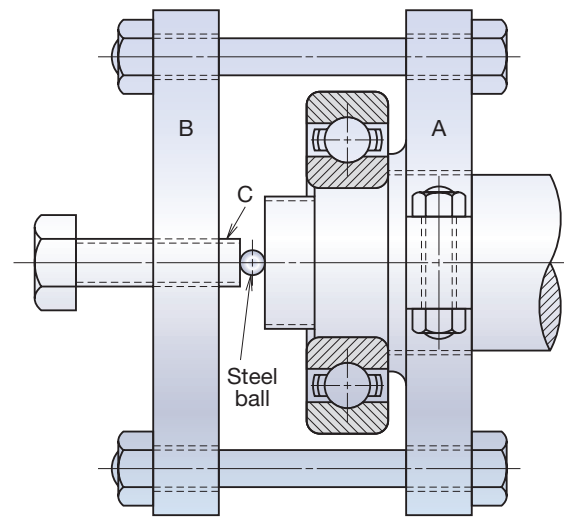

Fig. 44 Tool for Withdrawing an Inner Ring

must be fixed to prevent the bearing from rotating. When storing a cleaned bearing, it should be thoroughly dried and coated with an anti-corrosion agent. When applying grease, be sure to rotate the bearing to ensure uniform distribution to every part of the bearing.

4.4 Bearing Inspection

The term "inspection" here does not refer to the quantitative measurement of dimensional or rotational accuracy of the bearing, but simply refers to visual examination. Specifically, in order to investigate the condition of a bearing used for a given period, carefully note the presence of any abnormality and determine whether the bearing can easily be reused, completely clean the bearing as described above, and then look for visible

abnormalities such as rust, dents, or flaking in the raceway or the rolling element. Carefully inspect ball bearings for rotational smoothness. In addition, also check for creep in the fitting surface of the inner ring or the outer ring as well as any signs of serious abrasion. Also inspect the cage for wear, loose rivets or head defects. Defects most frequently occur when the rotational speed of the bearing is too high for the cage or when the lubricant is poor or insufficiently applied. Although a relatively large roller bearing can be measured for clearance with a clearance gauge, small bearings such as ball bearings cannot be measured by simply moving them by hand. An appropriate method must be applied to reliably determine the correct clearance. Refer to International Standards ISO 1132-2.

5 Bearing Storage

Since bearings are not intended for permanent use but must be replaced at given intervals, spare bearings must be stored in warehouse environments that are similar to operational conditions so they can be replaced immediately. When storing bearings, pay special attention to preventing rust. Although bearings are usually coated with an anti-corrosion agent and then packaged, the wrapping paper cannot completely provide protection from the circulation of ambient air. Therefore, bearings should be stored in a moisture-free location.

In addition, bearings should be stored in clean, well-ventilated spaces with little humidity and no direct exposure to sunlight, in a locker or on a shelf, at least 30 cm above the floor. The bearings must be kept wrapped unless otherwise required, since unwrapping them can allow rust to occur. When bearings are unwrapped for inspection prior to acceptance, they must be stored with due attention to the subsequent application of anti-corrosion agent and then re-packaged.

| Reference Catalog | |
|---|-----------------|
| New Bearing Doctor | (CAT. No. 7002) |
| Instruction Manual for Spherical Roller Bearing | (CAT. No. 9003) |
| Technical Report | (CAT. No. 728) |
| Instruction Manual for Roll Neck Bearing | (CAT. No. 9001) |

6 Appendices

Appendix Table 1 Tolerances for Shaft Diameters

Units: μm

| Diameter Classification (mm) | | Single Plane Mean B.D. Deviation (Normal) Δd_{mp} | d6 | e6 | f6 | g5 | g6 | h5 | h6 | h7 | h8 | h9 | h10 | js5 | js6 | j5 | j6 | j7 | k5 | k6 | k7 | m5 | m6 | n6 | p6 | r6 | r7 | Diameter Classification (mm) | |
|------------------------------|-------|---|----------------|---------------|--------------|--------------|--------------|-----------|-----------|-----------|-----------|------------|------------|-----------|------------|-------------|--------------|--------------|-------------|-------------|-------------|--------------|--------------|--------------|--------------|----------------|----------------|------------------------------|-------|
| over | incl. | | | | | | | | | | | | | | | | | | | | | | | | | | | over | incl. |
| 3 | 6 | 0 - 8 | - 30 - 38 | - 20 - 28 | - 10 - 18 | - 4 - 9 | - 4 - 12 | 0 - 5 | 0 - 8 | 0 - 12 | 0 - 18 | 0 - 30 | 0 - 48 | ± 2.5 | ± 4 | + 3 - 2 | + 6 - 2 | + 8 - 4 | + 6 + 1 | + 9 + 1 | + 13 + 1 | + 9 + 4 | + 12 + 4 | + 16 + 8 | + 20 + 12 | + 23 + 15 | + 27 + 15 | 3 | 6 |
| 6 | 10 | 0 - 8 | - 40 - 49 | - 25 - 34 | - 13 - 22 | - 5 - 11 | - 5 - 14 | 0 - 6 | 0 - 9 | 0 - 15 | 0 - 22 | 0 - 36 | 0 - 58 | ± 3 | ± 4.5 | + 4 - 2 | + 7 - 2 | + 10 - 5 | + 7 + 1 | + 10 + 1 | + 16 + 1 | + 12 + 6 | + 15 + 6 | + 19 + 10 | + 24 + 15 | + 28 + 19 | + 34 + 19 | 6 | 10 |
| 10 | 18 | 0 - 8 | - 50 - 61 | - 32 - 43 | - 16 - 27 | - 6 - 14 | - 6 - 17 | 0 - 8 | 0 - 11 | 0 - 18 | 0 - 27 | 0 - 43 | 0 - 70 | ± 4 | ± 5.5 | + 5 - 3 | + 8 - 3 | + 12 - 6 | + 9 + 1 | + 12 + 1 | + 19 + 1 | + 15 + 7 | + 18 + 7 | + 23 + 12 | + 29 + 18 | + 34 + 23 | + 41 + 23 | 10 | 18 |
| 18 | 30 | 0 - 10 | - 65 - 78 | - 40 - 53 | - 20 - 33 | - 7 - 16 | - 7 - 20 | 0 - 9 | 0 - 13 | 0 - 21 | 0 - 33 | 0 - 52 | 0 - 84 | ± 4.5 | ± 6.5 | + 5 - 4 | + 9 - 4 | + 13 - 8 | + 11 + 2 | + 15 + 2 | + 23 + 2 | + 17 + 8 | + 21 + 8 | + 28 + 15 | + 35 + 22 | + 41 + 28 | + 49 + 28 | 18 | 30 |
| 30 | 50 | 0 - 12 | - 80 - 96 | - 50 - 66 | - 25 - 41 | - 9 - 20 | - 9 - 25 | 0 - 11 | 0 - 16 | 0 - 25 | 0 - 39 | 0 - 62 | 0 - 100 | ± 5.5 | ± 8 | + 6 - 5 | + 11 - 5 | + 15 - 10 | + 13 + 2 | + 18 + 2 | + 27 + 2 | + 20 + 9 | + 25 + 9 | + 33 + 17 | + 42 + 26 | + 50 + 34 | + 59 + 34 | 30 | 50 |
| 50 | 80 | 0 - 15 | - 100 - 119 | - 60 - 79 | - 30 - 49 | - 10 - 23 | - 10 - 29 | 0 - 13 | 0 - 19 | 0 - 30 | 0 - 46 | 0 - 74 | 0 - 120 | ± 6.5 | ± 9.5 | + 6 - 7 | + 12 - 7 | + 18 - 12 | + 15 + 2 | + 21 + 2 | + 32 + 2 | + 24 + 11 | + 30 + 11 | + 39 + 20 | + 51 + 32 | + 60 + 41 | + 71 + 41 | 50 | 65 |
| 80 | 120 | 0 - 20 | - 120 - 142 | - 72 - 94 | - 36 - 58 | - 12 - 27 | - 12 - 34 | 0 - 15 | 0 - 22 | 0 - 35 | 0 - 54 | 0 - 87 | 0 - 140 | ± 7.5 | ± 11 | + 6 - 9 | + 13 - 9 | + 20 - 15 | + 18 + 3 | + 25 + 3 | + 38 + 3 | + 28 + 13 | + 35 + 13 | + 45 + 23 | + 59 + 37 | + 73 + 51 | + 86 + 51 | 80 | 100 |
| 120 | 180 | 0 - 25 | - 145 - 170 | - 85 - 110 | - 43 - 68 | - 14 - 32 | - 14 - 39 | 0 - 18 | 0 - 25 | 0 - 40 | 0 - 63 | 0 - 100 | 0 - 160 | ± 9 | ± 12.5 | + 7 - 11 | + 14 - 11 | + 22 - 18 | + 21 + 3 | + 28 + 3 | + 43 + 3 | + 33 + 15 | + 40 + 15 | + 52 + 27 | + 68 + 43 | + 88 + 63 | + 103 + 63 | 120 | 140 |
| 140 | 160 | | | | | | | | | | | | | | | | | | | | | | | | | + 90 + 65 | + 105 + 65 | 140 | 160 |
| 160 | 180 | | | | | | | | | | | | | | | | | | | | | | | | | + 93 + 68 | + 108 + 68 | 160 | 180 |
| 180 | 200 | | | | | | | | | | | | | | | | | | | | | | | | | + 106 + 77 | + 123 + 77 | 180 | 200 |
| 200 | 225 | | | | | | | | | | | | | | | | | | | | | | | | | + 109 + 80 | + 126 + 80 | 200 | 225 |
| 225 | 250 | | | | | | | | | | | | | | | | | | | | | | | | | + 113 + 84 | + 130 + 84 | 225 | 250 |
| 250 | 280 | | | | | | | | | | | | | | | | | | | | | | | | | + 126 + 94 | + 146 + 94 | 250 | 280 |
| 280 | 315 | | | | | | | | | | | | | | | | | | | | | | | | | + 130 + 98 | + 150 + 98 | 280 | 315 |
| 315 | 355 | | | | | | | | | | | | | | | | | | | | | | | | | + 144 + 108 | + 165 + 108 | 315 | 355 |
| 355 | 400 | | | | | | | | | | | | | | | | | | | | | | | | | + 150 + 114 | + 171 + 114 | 355 | 400 |
| 400 | 450 | | | | | | | | | | | | | | | | | | | | | | | | | + 166 + 126 | + 189 + 126 | 400 | 450 |
| 450 | 500 | | | | | | | | | | | | | | | | | | | | | | | | | + 172 + 132 | + 195 + 132 | 450 | 500 |
| 500 | 560 | | | | | | | | | | | | | | | | | | | | | | | | | + 194 + 150 | + 220 + 150 | 500 | 560 |
| 560 | 630 | | | | | | | | | | | | | | | | | | | | | | | | | + 199 + 155 | + 225 + 155 | 560 | 630 |
| 630 | 710 | | | | | | | | | | | | | | | | | | | | | | | | | + 225 + 175 | + 255 + 175 | 630 | 710 |
| 710 | 800 | | | | | | | | | | | | | | | | | | | | | | | | | + 235 + 185 | + 265 + 185 | 710 | 800 |
| 800 | 900 | | | | | | | | | | | | | | | | | | | | | | | | | + 266 + 210 | + 300 + 210 | 800 | 900 |
| 900 | 1 000 | | | | | | | | | | | | | | | | | | | | | | | | | + 276 + 220 | + 310 + 220 | 900 | 1 000 |
| 1 000 | 1 120 | | | | | | | | | | | | | | | | | | | | | | | | | + 316 + 250 | + 355 + 250 | 1 000 | 1 120 |
| 1 120 | 1 250 | | | | | | | | | | | | | | | | | | | | | | | | | + 326 + 260 | + 365 + 260 | 1 120 | 1 250 |
| 1 250 | 1 400 | | | | | | | | | | | | | | | | | | | | | | | | | + 378 + 300 | + 425 + 300 | 1 250 | 1 400 |
| 1 400 | 1 600 | | | | | | | | | | | | | | | | | | | | | | | | | + 408 + 330 | + 455 + 330 | 1 400 | 1 600 |
| 1 600 | 1 800 | | | | | | | | | | | | | | | | | | | | | | | | | + 462 + 370 | + 520 + 370 | 1 600 | 1 800 |
| 1 800 | 2 000 | | | | | | | | | | | | | | | | | | | | | | | | | + 492 + 400 | + 550 + 400 | 1 800 | 2 000 |

Appendix Table 2 Tolerances for Housing Bore Diameters

Units: μm

| Diameter Classification (mm) | | Single Plane Mean B.D. Deviation (Normal) ΔDmp | E6 | F6 | F7 | G6 | G7 | H6 | H7 | H8 | J6 | J7 | JS6 | JS7 | K5 | K6 | K7 | M5 | M6 | M7 | N5 | N6 | N7 | P6 | P7 | Diameter Classification (mm) | |
|------------------------------|-------|--|--------------|--------------|--------------|--------------|--------------|-----------|-----------|-----------|-------------|--------------|------------|------------|-------------|-------------|--------------|--------------|--------------|--------------|--------------|--------------|--------------|--------------|--------------|------------------------------|-------|
| over | incl. | | | | | | | | | | | | | | | | | | | | | | | | | over | incl. |
| 10 | 18 | 0 - 8 | + 43 + 32 | + 27 + 16 | + 34 + 16 | + 17 + 6 | + 24 + 6 | + 11 0 | + 18 0 | + 27 0 | + 6 - 5 | + 10 - 8 | \pm 5.5 | \pm 9 | + 2 - 6 | + 2 - 9 | + 6 - 12 | - 4 - 12 | - 4 - 15 | 0 - 18 | - 9 - 17 | - 9 - 20 | - 5 - 23 | - 15 - 26 | - 11 - 29 | 10 | 18 |
| 18 | 30 | 0 - 9 | + 53 + 40 | + 33 + 20 | + 41 + 20 | + 20 + 7 | + 28 + 7 | + 13 0 | + 21 0 | + 33 0 | + 8 - 5 | + 12 - 9 | \pm 6.5 | \pm 10.5 | + 1 - 8 | + 2 - 11 | + 6 - 15 | - 5 - 14 | - 4 - 17 | 0 - 21 | - 12 - 21 | - 11 - 24 | - 7 - 28 | - 18 - 31 | - 14 - 35 | 18 | 30 |
| 30 | 50 | 0 - 11 | + 66 + 50 | + 41 + 25 | + 50 + 25 | + 25 + 9 | + 34 + 9 | + 16 0 | + 25 0 | + 39 0 | + 10 - 6 | + 14 - 11 | \pm 8 | \pm 12.5 | + 2 - 9 | + 3 - 13 | + 7 - 18 | - 5 - 16 | - 4 - 20 | 0 - 25 | - 13 - 24 | - 12 - 28 | - 8 - 33 | - 21 - 37 | - 17 - 42 | 30 | 50 |
| 50 | 80 | 0 - 13 | + 79 + 60 | + 49 + 30 | + 60 + 30 | + 29 + 10 | + 40 + 10 | + 19 0 | + 30 0 | + 46 0 | + 13 - 6 | + 18 - 12 | \pm 9.5 | \pm 15 | + 3 - 10 | + 4 - 15 | + 9 - 21 | - 6 - 19 | - 5 - 24 | 0 - 30 | - 15 - 28 | - 14 - 33 | - 9 - 39 | - 26 - 45 | - 21 - 51 | 50 | 80 |
| 80 | 120 | 0 - 15 | + 94 + 72 | + 58 + 36 | + 71 + 36 | + 34 + 12 | + 47 + 12 | + 22 0 | + 35 0 | + 54 0 | + 16 - 6 | + 22 - 13 | \pm 11 | \pm 17.5 | + 2 - 13 | + 4 - 18 | + 10 - 25 | - 8 - 23 | - 6 - 28 | 0 - 35 | - 18 - 33 | - 16 - 38 | - 10 - 45 | - 30 - 52 | - 24 - 59 | 80 | 120 |
| 120 | 150 | 0 - 18 | +110 + 85 | + 68 + 43 | + 83 + 43 | + 39 + 14 | + 54 + 14 | + 25 0 | + 40 0 | + 63 0 | + 18 - 7 | + 26 - 14 | \pm 12.5 | \pm 20 | + 3 - 15 | + 4 - 21 | + 12 - 28 | - 9 - 27 | - 8 - 33 | 0 - 40 | - 21 - 39 | - 20 - 45 | - 12 - 52 | - 36 - 61 | - 28 - 68 | 120 | 180 |
| 150 | 180 | 0 - 25 | +110 + 85 | + 68 + 43 | + 83 + 43 | + 39 + 14 | + 54 + 14 | + 25 0 | + 40 0 | + 63 0 | + 18 - 7 | + 26 - 14 | \pm 12.5 | \pm 20 | + 3 - 15 | + 4 - 21 | + 12 - 28 | - 9 - 27 | - 8 - 33 | 0 - 40 | - 21 - 39 | - 20 - 45 | - 12 - 52 | - 36 - 61 | - 28 - 68 | 120 | 180 |
| 180 | 250 | 0 - 30 | +129 +100 | + 79 + 50 | + 96 + 50 | + 44 + 15 | + 61 + 15 | + 29 0 | + 46 0 | + 72 0 | + 22 - 7 | + 30 - 16 | \pm 14.5 | \pm 23 | + 2 - 18 | + 5 - 24 | + 13 - 33 | - 11 - 31 | - 8 - 37 | 0 - 46 | - 25 - 45 | - 22 - 51 | - 14 - 60 | - 41 - 70 | - 33 - 79 | 180 | 250 |
| 250 | 315 | 0 - 35 | +142 +110 | + 88 + 56 | +108 + 56 | + 49 + 17 | + 69 + 17 | + 32 0 | + 52 0 | + 81 0 | + 25 - 7 | + 36 - 16 | \pm 16 | \pm 26 | + 3 - 20 | + 5 - 27 | + 16 - 36 | - 13 - 36 | - 9 - 41 | 0 - 52 | - 27 - 50 | - 25 - 57 | - 14 - 66 | - 47 - 79 | - 36 - 88 | 250 | 316 |
| 315 | 400 | 0 - 40 | +161 +125 | + 98 + 62 | +119 + 62 | + 54 + 18 | + 75 + 18 | + 36 0 | + 57 0 | + 89 0 | + 29 - 7 | + 39 - 18 | \pm 18 | \pm 28.5 | + 3 - 22 | + 7 - 29 | + 17 - 40 | - 14 - 39 | - 10 - 46 | 0 - 57 | - 30 - 55 | - 26 - 62 | - 16 - 73 | - 51 - 87 | - 41 - 98 | 315 | 400 |
| 400 | 500 | 0 - 45 | +175 +135 | +108 + 68 | +131 + 68 | + 60 + 20 | + 83 + 20 | + 40 0 | + 63 0 | + 97 0 | + 33 - 7 | + 43 - 20 | \pm 20 | \pm 31.5 | + 2 - 25 | + 8 - 32 | + 18 - 45 | - 16 - 43 | - 10 - 50 | 0 - 63 | - 33 - 60 | - 27 - 67 | - 17 - 80 | - 55 - 95 | - 45 -108 | 400 | 500 |
| 500 | 630 | 0 - 50 | +189 +145 | +120 + 76 | +146 + 76 | + 66 + 22 | + 92 + 22 | + 44 0 | + 70 0 | +110 0 | - | - | \pm 22 | \pm 35 | - | 0 - 44 | 0 - 70 | - | - 26 - 70 | - 26 - 96 | - | - 44 - 88 | - 44 -114 | - 78 -122 | - 78 -148 | 500 | 630 |
| 630 | 800 | 0 - 75 | +210 +160 | +130 + 80 | +160 + 80 | + 74 + 24 | +104 + 24 | + 50 0 | + 80 0 | +125 0 | - | - | \pm 25 | \pm 40 | - | 0 - 50 | 0 - 80 | - | - 30 - 80 | - 30 -110 | - | - 50 -100 | - 50 -130 | - 88 -138 | - 88 -168 | 630 | 800 |
| 800 | 1 000 | 0 -100 | +226 +170 | +142 + 86 | +176 + 86 | + 82 + 26 | +116 + 26 | + 56 0 | + 90 0 | +140 0 | - | - | \pm 28 | \pm 45 | - | 0 - 56 | 0 - 90 | - | - 34 - 90 | - 34 -124 | - | - 56 -112 | - 56 -146 | -100 -156 | -100 -190 | 800 | 1 000 |
| 1 000 | 1 250 | 0 -125 | +261 +195 | +164 + 98 | +203 + 98 | + 94 + 28 | +133 + 28 | + 66 0 | +105 0 | +165 0 | - | - | \pm 33 | \pm 52.5 | - | 0 - 66 | 0 -105 | - | - 40 -106 | - 40 -145 | - | - 66 -132 | - 66 -171 | -120 -186 | -120 -225 | 1 000 | 1 250 |
| 1 250 | 1 600 | 0 -160 | +298 +220 | +188 +110 | +235 +110 | +108 + 30 | +155 + 30 | + 78 0 | +125 0 | +195 0 | - | - | \pm 39 | \pm 62.5 | - | 0 - 78 | 0 -125 | - | - 48 -126 | - 48 -173 | - | - 78 -156 | - 78 -203 | -140 -218 | -140 -265 | 1 250 | 1 600 |
| 1 600 | 2 000 | 0 -200 | +332 +240 | +212 +120 | +270 +120 | +124 + 32 | +182 + 32 | + 92 0 | +150 0 | +230 0 | - | - | \pm 46 | \pm 75 | - | 0 - 92 | 0 -150 | - | - 58 -150 | - 58 -208 | - | - 92 -184 | - 92 -242 | -170 -262 | -170 -320 | 1 600 | 2 000 |
| 2 000 | 2 500 | 0 -250 | +370 +260 | +240 +130 | +305 +130 | +144 + 34 | +209 + 34 | +110 0 | +175 0 | +280 0 | - | - | \pm 55 | \pm 87.5 | - | 0 -110 | 0 -175 | - | - 68 -178 | - 68 -243 | - | -110 -220 | -110 -285 | -195 -305 | -195 -370 | 2 000 | 2 500 |

Appendix Table 3 Values of Standard Tolerance Grades IT

| Basic Size (mm) | | Standard Grades | | | | | | | | | | | | | | | | | | Basic Size (mm) | |
|--------------------|-------|-----------------|-----|-----|-----|-----|-----|-----|-----|-----|------|-------|-----------------|------|------|------|-------|-------|-------|--------------------|-------|
| | | IT1 | IT2 | IT3 | IT4 | IT5 | IT6 | IT7 | IT8 | IT9 | IT10 | IT11 | IT12 | IT13 | IT14 | IT15 | IT16 | IT17 | IT18 | | |
| over | incl. | Tolerances (μm) | | | | | | | | | | | Tolerances (μm) | | | | | | over | incl. | |
| – | 3 | 0.8 | 1.2 | 2 | 3 | 4 | 6 | 10 | 14 | 25 | 40 | 60 | 0.10 | 0.14 | 0.26 | 0.40 | 0.60 | 1.00 | 1.40 | – | 3 |
| 3 | 6 | 1 | 1.5 | 2.5 | 4 | 5 | 8 | 12 | 18 | 30 | 48 | 75 | 0.12 | 0.18 | 0.30 | 0.48 | 0.75 | 1.20 | 1.80 | 3 | 6 |
| 6 | 10 | 1 | 1.5 | 2.5 | 4 | 6 | 9 | 15 | 22 | 36 | 58 | 90 | 0.15 | 0.22 | 0.36 | 0.58 | 0.90 | 1.50 | 2.20 | 6 | 10 |
| 10 | 18 | 1.2 | 2 | 3 | 5 | 8 | 11 | 18 | 27 | 43 | 70 | 110 | 0.18 | 0.27 | 0.43 | 0.70 | 1.10 | 1.80 | 2.70 | 10 | 18 |
| 18 | 30 | 1.5 | 2.5 | 4 | 6 | 9 | 13 | 21 | 33 | 52 | 84 | 130 | 0.21 | 0.33 | 0.52 | 0.84 | 1.30 | 2.10 | 3.30 | 18 | 30 |
| 30 | 50 | 1.5 | 2.5 | 4 | 7 | 11 | 16 | 25 | 39 | 62 | 100 | 160 | 0.25 | 0.39 | 0.62 | 1.00 | 1.60 | 2.50 | 3.90 | 30 | 50 |
| 50 | 80 | 2 | 3 | 5 | 8 | 13 | 19 | 30 | 46 | 74 | 120 | 190 | 0.30 | 0.46 | 0.74 | 1.20 | 1.90 | 3.00 | 4.60 | 50 | 80 |
| 80 | 120 | 2.5 | 4 | 6 | 10 | 15 | 22 | 35 | 54 | 87 | 140 | 220 | 0.35 | 0.54 | 0.87 | 1.40 | 2.20 | 3.50 | 5.40 | 80 | 120 |
| 120 | 180 | 3.5 | 5 | 8 | 12 | 18 | 25 | 40 | 63 | 100 | 160 | 250 | 0.40 | 0.63 | 1.00 | 1.60 | 2.50 | 4.00 | 6.30 | 120 | 180 |
| 180 | 250 | 4.5 | 7 | 10 | 14 | 20 | 29 | 46 | 72 | 115 | 185 | 290 | 0.46 | 0.72 | 1.15 | 1.85 | 2.90 | 4.60 | 7.20 | 180 | 250 |
| 250 | 315 | 6 | 8 | 12 | 16 | 23 | 32 | 52 | 81 | 130 | 210 | 320 | 0.52 | 0.81 | 1.30 | 2.10 | 3.20 | 5.20 | 8.10 | 250 | 315 |
| 315 | 400 | 7 | 9 | 13 | 18 | 25 | 36 | 57 | 89 | 140 | 230 | 360 | 0.57 | 0.89 | 1.40 | 2.30 | 3.60 | 5.70 | 8.90 | 315 | 400 |
| 400 | 500 | 8 | 10 | 15 | 20 | 27 | 40 | 63 | 97 | 155 | 250 | 400 | 0.63 | 0.97 | 1.55 | 2.50 | 4.00 | 6.30 | 9.70 | 400 | 500 |
| 500 | 630 | 9 | 11 | 16 | 22 | 30 | 44 | 70 | 110 | 175 | 280 | 440 | 0.70 | 1.10 | 1.75 | 2.80 | 4.40 | 7.00 | 11.00 | 500 | 630 |
| 630 | 800 | 10 | 13 | 18 | 25 | 35 | 50 | 80 | 125 | 200 | 320 | 500 | 0.80 | 1.25 | 2.00 | 3.20 | 5.00 | 8.00 | 12.50 | 630 | 800 |
| 800 | 1 000 | 11 | 15 | 21 | 29 | 40 | 56 | 90 | 140 | 230 | 360 | 560 | 0.90 | 1.40 | 2.30 | 3.60 | 5.60 | 9.00 | 14.00 | 800 | 1 000 |
| 1 000 | 1 250 | 13 | 18 | 24 | 34 | 46 | 66 | 105 | 165 | 260 | 420 | 660 | 1.05 | 1.65 | 2.60 | 4.20 | 6.60 | 10.50 | 16.50 | 1 000 | 1 250 |
| 1 250 | 1 600 | 15 | 21 | 29 | 40 | 54 | 78 | 125 | 195 | 310 | 500 | 780 | 1.25 | 1.95 | 3.10 | 5.00 | 7.80 | 12.50 | 19.50 | 1 250 | 1 600 |
| 1 600 | 2 000 | 18 | 25 | 35 | 48 | 65 | 92 | 150 | 230 | 370 | 600 | 920 | 1.50 | 2.30 | 3.70 | 6.00 | 9.20 | 15.00 | 23.00 | 1 600 | 2 000 |
| 2 000 | 2 500 | 22 | 30 | 41 | 57 | 77 | 110 | 175 | 280 | 440 | 700 | 1 100 | 1.75 | 2.80 | 4.40 | 7.00 | 11.00 | 17.50 | 28.00 | 2 000 | 2 500 |
| 2 500 | 3 150 | 26 | 36 | 50 | 69 | 93 | 135 | 210 | 330 | 540 | 860 | 1 350 | 2.10 | 3.30 | 5.40 | 8.60 | 13.50 | 21.00 | 33.00 | 2 500 | 3 150 |

Remarks 1. Standard tolerance grades IT 14 to IT 18 must not be used for basic sizes less than or equal to 1 mm.
 2. Values for standard tolerance grades IT 1 to IT 5 for basic sizes over 500 mm are included for experimental use.