

# BNR/BER ROBUST Series High-Speed Precision Angular Contact Ball Bearings for Machine Tool Spindles

- Temperature tolerance and low heat generation
- Smooth running even during rapid acceleration
- Higher speed and longer life



## Features

*Bearing features indispensable to motorized main spindles—temperature tolerance, seizure resistance and low heat generation—have been improved to enable higher speeds with minimal thermal deformation.*

A major trend in the machine tool industry is for higher maximum spindle speeds. In addition, machines are being required to perform a wider variety of tasks and undergo frequent tool changes. Under such conditions, excellent high-speed performance is imperative and spindles must accelerate and decelerate faster. During periods of rapid acceleration or deceleration, spindle bearings are subjected to severe thermal load conditions. These conditions are caused by drastic changes in the ambient environment that result from heat generated by the motor, housing cooling and other factors. Performing well under such conditions and being capable of higher speeds than conventional precision bearings, the ROBUST Series bearings provide solutions for high-speed spindles of the 21st century.

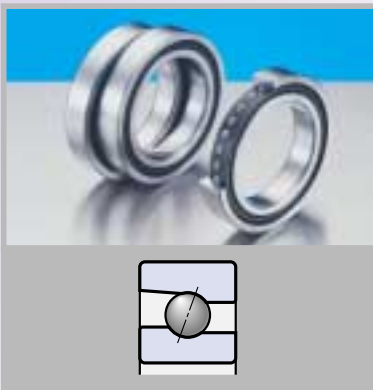

**S type** (balls and rings: bearing steel)

**H type** (balls: silicon nitride,  $\text{Si}_3\text{N}_4$ /rings: bearing steel)

These bearings are designed for motorized and non-motorized spindles and feature the optimal internal structure for minimizing heat generation and improving seizure resistance. The H type can be lubricated with grease at speeds where conventional bearings require Oil-Air lubrication. Additionally, both the S type and H type are capable of speeds 20% higher than conventional precision angular contact ball bearings.



**X type** (balls: silicon nitride,  $\text{Si}_3\text{N}_4$ /rings: SHX steel)

While this hybrid ceramic bearing has the same design as the S and H types, its rings are made of SHX steel, a new steel developed by NSK. SHX has excellent seizure and wear resistance during critical lubrication shortages. Also, its heat resistance is nearly equal to M50 steel, which is widely used in bearings for jet aircraft engines. With the X type, grease lubrication is feasible at even higher speeds than the H type. In terms of both surface and subsurface fatigue, SHX steel provides longer life.



**XE type** (balls: silicon nitride,  $\text{Si}_3\text{N}_4$ /rings: SHX steel/Spinshot™ Technology)

XE bearings have the same specifications as the X type, but employ NSK's exclusive Spinshot™ lubrication system. While previously only oil jet lubrication has been feasible at speeds exceeding 2,000,000  $d_m n$ , the Spinshot™ lubrication system utilizes a mixture of oil and air to enable the XE type to sustain such speeds. The use of Oil-Air instead of oil jets reduces overall costs by allowing the structure of the spindle to be simplified and cutting down on the consumption of oil, an added environmental benefit.

\* Please note that the XE type is not dimensionally interchangeable with conventional precision angular contact ball bearings.

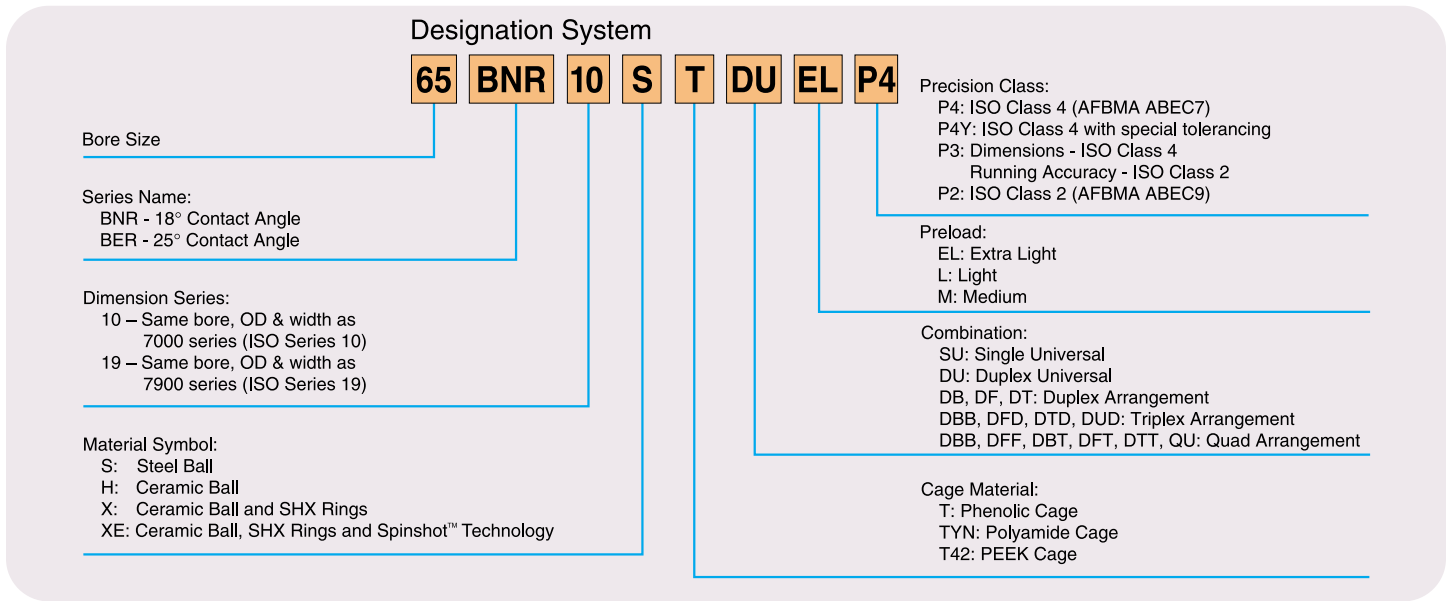

## High performance



### Spinshot XE Type

Suitable for silent operation due to reduced air-noise achieved through Oil-Air lubrication design.

- Material of Inner/Outer Rings: Special High speed Steel “SHX”
- Ceramic balls
- Cage selection based on speed requirements – Outer Ring Guided Phenolic cage: up to 2.5 million  $d_m n$ .; Outer Ring Guided PEEK cage: over 2.5 million  $d_m n$ .

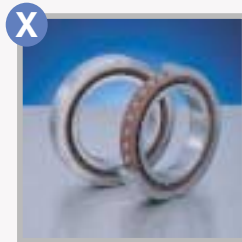

### ROBUST Series X Type

High performance bearings demonstrating high wear and seizure resistance at ultra high speed operation.

- Material of Inner/Outer Rings: Special High speed Steel “SHX”
- Ceramic balls
- Outer Ring Guided Phenolic cage

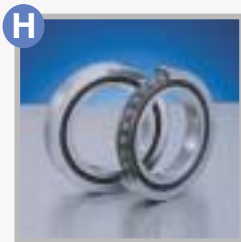

### ROBUST Series H Type

High performance bearings that combine high speed operation with low heat generation.

- Material of Inner/Outer Rings: SUJ2
- Ceramic balls
- Cage selection based on speed requirement – Ball Guided Polyamide cage: up to 1.4 million  $d_m n$ .; Outer Ring Guided Phenolic cage: over 1.4 million  $d_m n$ .

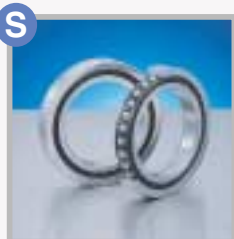

### ROBUST Series S Type

Steel ball bearings for optimal cost.

- Material of Inner/Outer Rings: SUJ2
- Steel balls
- Cage selection based on speed requirement – Ball Guided Polyamide cage: up to 1.4 million  $d_m n$ .; Outer Ring Guided Phenolic cage: over 1.4 million  $d_m n$ .

**High speed**

## Features of "SHX" material

"SHX" has similar heat-resistant performance to "M50," which is used in bearings for jet engines and can operate at temperatures up to 300°C. However, "SHX" steel provides even better wear and seizure resistance and longer life than "M50."

"SHX" is the most suitable material for high-speed bearings with EHL lubrication, such as oil-air lubrication or grease lubrication. These conditions are typical of main shaft spindles in machine tools.

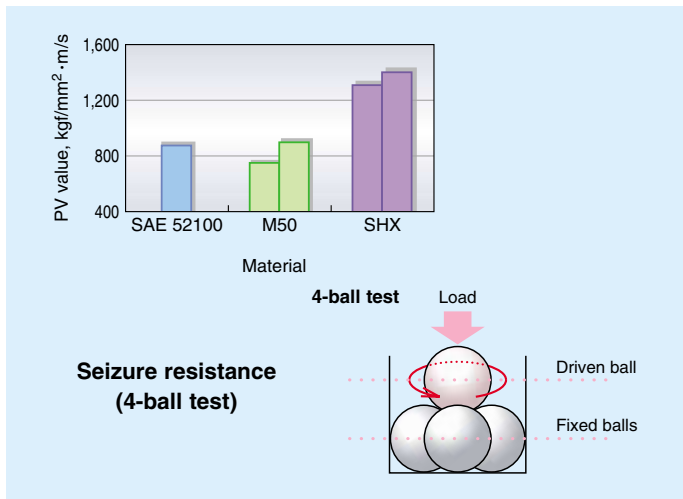
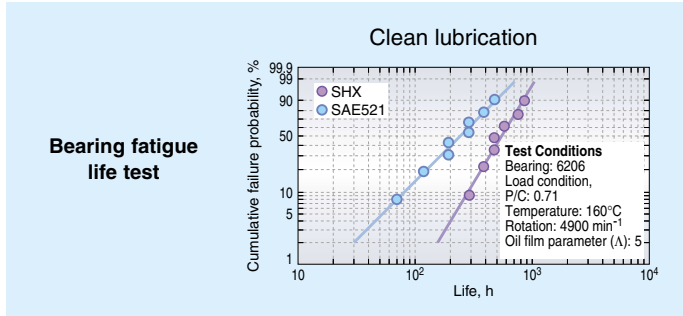

## Features of Optimal Internal Design

Today, machining involves various cutting conditions within a wide range of speeds. Consequently, spindle temperatures vary widely and cause changes in internal bearing load. The unique design of the ROBUST Series bearings minimizes the adverse effect temperature variation has on internal bearing load.

To ensure the accuracy of spindles by minimizing thermal displacement, suppression of bearing dynamic frictional loss is vital. The ROBUST series design controls dynamic frictional loss, reducing heat generation by approximately 20% when compared to conventional bearings at the same speed.

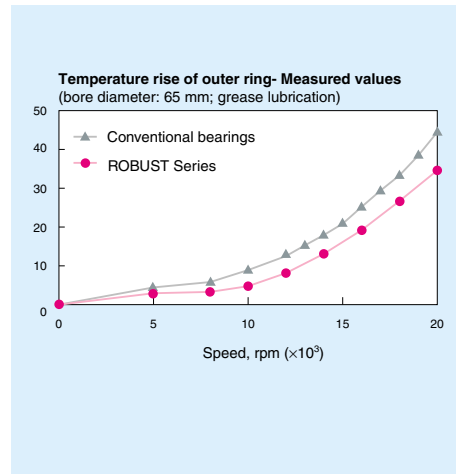

M

Improvement of cleanliness

High cleanliness

Special melting

SU

VIM-VAR for aircraft and high-reliability use

EP Steel (ISD2+SN)

Used TAC s

## Features of ceramic ball angular contact ball bearings



- Limiting speed is 20% to 50% higher than steel ball bearings.
- 40% lower density than steel balls provides lower centrifugal force.
- Ceramic balls provide reduced operating preload due to lower thermal expansion and less ball slipping.
- Ceramic balls are 50% more rigid than steel balls, which provides high-rigidity for main shaft bearings.
- NSK's improved ceramic ball material provides high-accuracy.

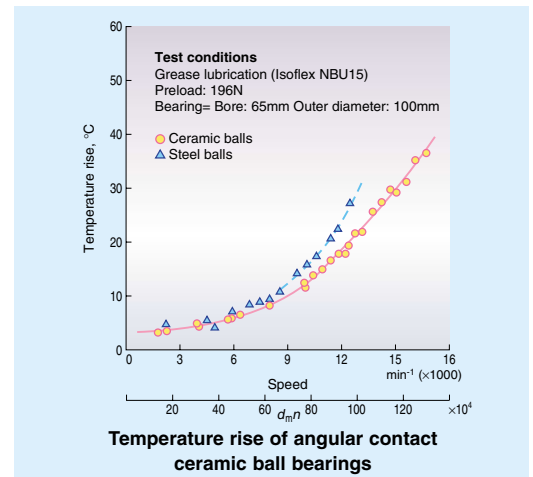

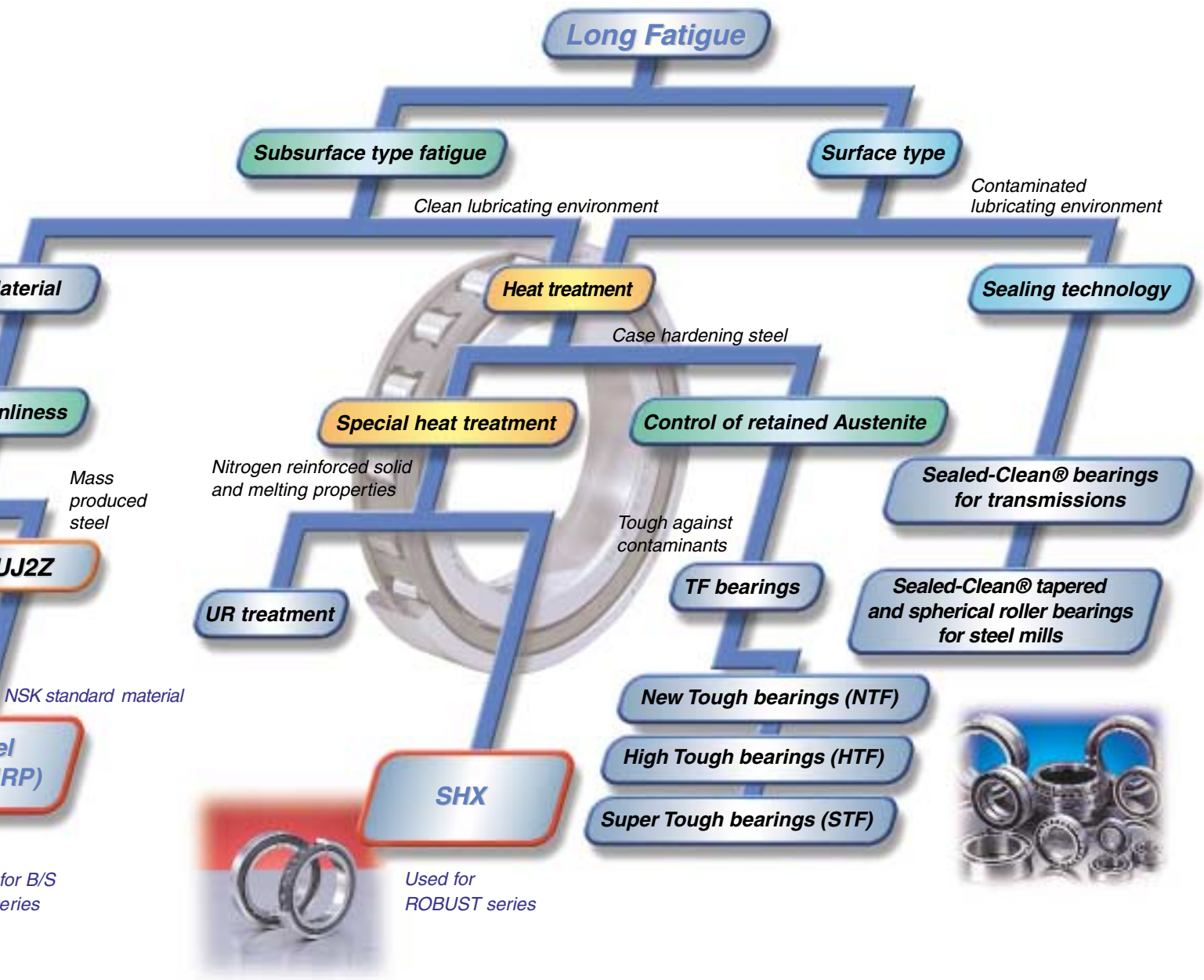

## Features of TYN Cage

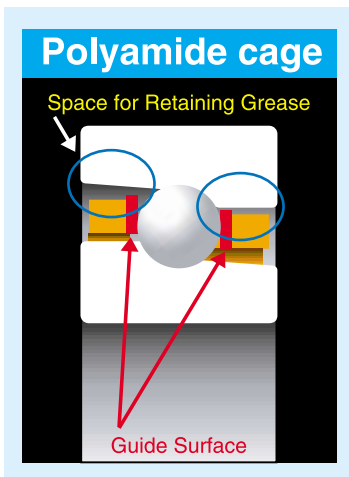

- Ball guided polyamide cage reinforced with glass fiber.
- Better for keeping grease on the outer ring due to space between the cage and outer ring.
- Low temperature rise (up to 1.4 million  $d_m n$ ).
- Noise reduction (under grease lubrication).
- Potential for reduced run-in procedure time (under grease lubrication).

## Features of T Cage

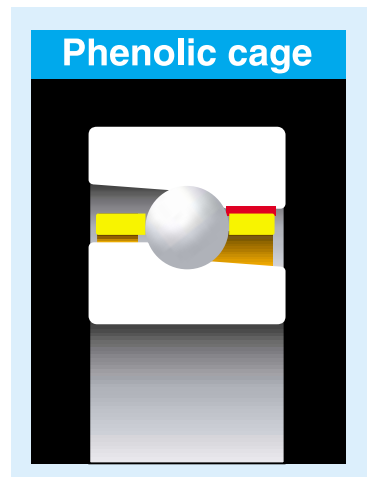

- Phenolic material and design provide stable operation at high speeds (higher than 1.4 million  $d_m n$ ).
- For Oil-Air and oil-mist lubrication, an outer ring guided cage enables better oil flow.

# High Speed Precision Angular Contact Ball Bearings

## Limiting Speed

The limiting speeds listed in the Bearing Dimensional Tables are guideline values. They are based on a single bearing that is lightly preloaded by means of a spring and subjected to relatively light loads with good heat dissipation.

The limiting speeds with grease lubrication are determined using high-quality grease in appropriate amounts. Those listed for oil lubrication are based on the use of Oil-Air (or oil mist) lubrication.

Note: When single bearings are used in duplex, triplex, and quad combinations, or the preload is increased to improve spindle rigidity, limiting speeds will be lower than those listed.



## Speed Factors (1)

The limiting speed of a matched bearing set operating under position preload conditions is calculated by multiplying the limiting speed of a single bearing in the set by the appropriate adjustment factor listed in the table below.

## Sample Calculation

A customer wants to use 70BNR10HTDBBP4Y (a quad set) at the spindle's tool-side, greased bearings, at 12000 rpm. What is the approximate maximum limiting speed for the bearing set with light preload?

Obtain the "single" bearing maximum speed (20000 rpm) for grease from the bearing tables, page 13. Calculate the approximate maximum limiting speed for the DBB set with light preload using the speed factor (0.75) from the table above, by multiplying the single bearing speed times the speed factor:  $20000 \times 0.75 = 15000$  rpm. Since the customer's spindle speed, 12000 rpm, is below the allowable 15000 rpm, the customer's choice of bearing and preload appears appropriate.

	Arrangement	EL	L	M
DB		0.85	0.80	0.65
DBD		0.75	0.70	0.55
DBB		0.80	0.75	0.60

## Factors that Change Preload

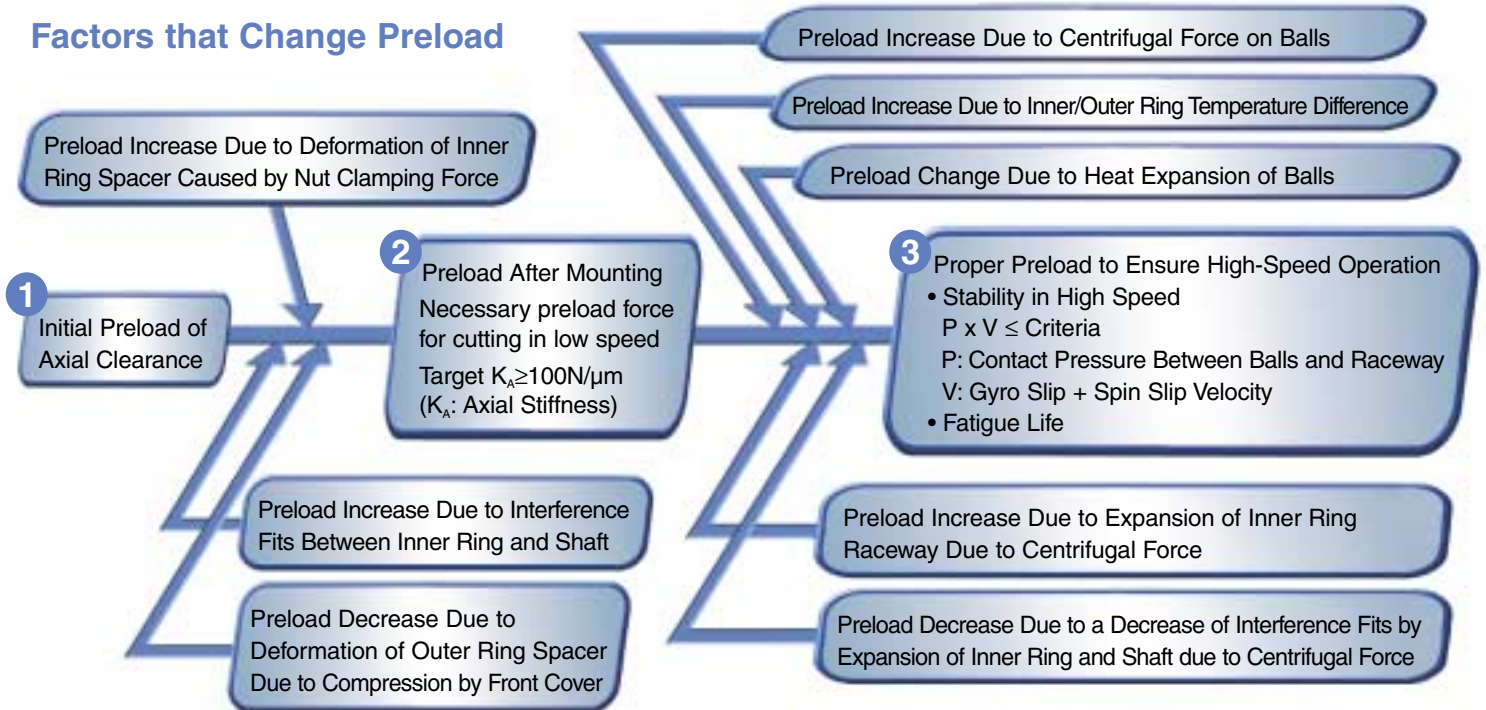

(1) CAUTION: Preload means the preload values after the bearing has been mounted on the spindle. These after mounted pre-load values will change as a result of the shaft fit requirement of high speed operation and spacer deformation due to nut clamping force. In such case, particular in high speed applications, it is necessary to adjust the spacer lengths relative to each other in order to compensate for the changes in preload after bearing mounting. Consult NSK for guidance.

## Fitting of Bearings

The recommended fits under normal operating conditions (inner ring rotation) for machine-tool spindles are shown in the tables below.

### FITS (1) ON SHAFTS

Bearing Type	Shaft O.D.		Shaft O.D. (2) Tolerance (mm)		Target Interference (3)(4) (mm)	
	over	incl	minimum	maximum	minimum	maximum
Main Spindle Bearings	10	18	- 0.003	0	0	0.002 T
	18	50	- 0.004	0	0	0.0025 T
	50	80	- 0.005	0	0	0.003 T
	80	120	- 0.003	0.003	0	0.004 T
	120	180	- 0.004	0.004	0	0.004 T
	180	250	- 0.005	0.005	0	0.005 T

### FITS (1) ON HOUSING

Bearing Type	Housing Bore		Housing Bore (2) Tolerance (mm)		Target Interference (3)(4) (mm)	
	over	incl	minimum	maximum	minimum	maximum
Angular Contact Ball Bearing (Fixed side)	18	50	- 0.002	0.002	0.002 L	0.006 L
	50	80	- 0.0025	0.0025	0.002 L	0.006 L
	80	120	- 0.003	0.003	0.003 L	0.008 L
	120	180	- 0.004	0.004	0.003 L	0.008 L
	180	250	- 0.005	0.005	0.005 L	0.010 L
Angular Contact Ball Bearing (Free side)	18	50	0	0.004	0.006 L	0.011 L
	50	80	0	0.005	0.006 L	0.011 L
	80	120	0	0.006	0.009 L	0.015 L
	120	180	0	0.008	0.009 L	0.015 L
	180	250	0	0.010	0.015 L	0.022 L

Notes (1) The "fits" data above are general recommendations for machine tool spindles operating under normal conditions (inner ring rotation), and for  $d_m n$  values less than 800,000. Where  $d_m n = \{[(\text{Bearing ID} + \text{OD})/2] * \text{RPM}\}$ .

For high-speeds, high loads, or outer ring rotation, consult NSK for fit recommendations.

(2) Use "Target" Interference when the bearings can be matched to the shaft or housing. Otherwise use Shaft OD and Housing Bore min. & max. for random matching.

(3) T=Interference of tight fit; L=Clearance or loose fit.

## Spindle Bearing Arrangement

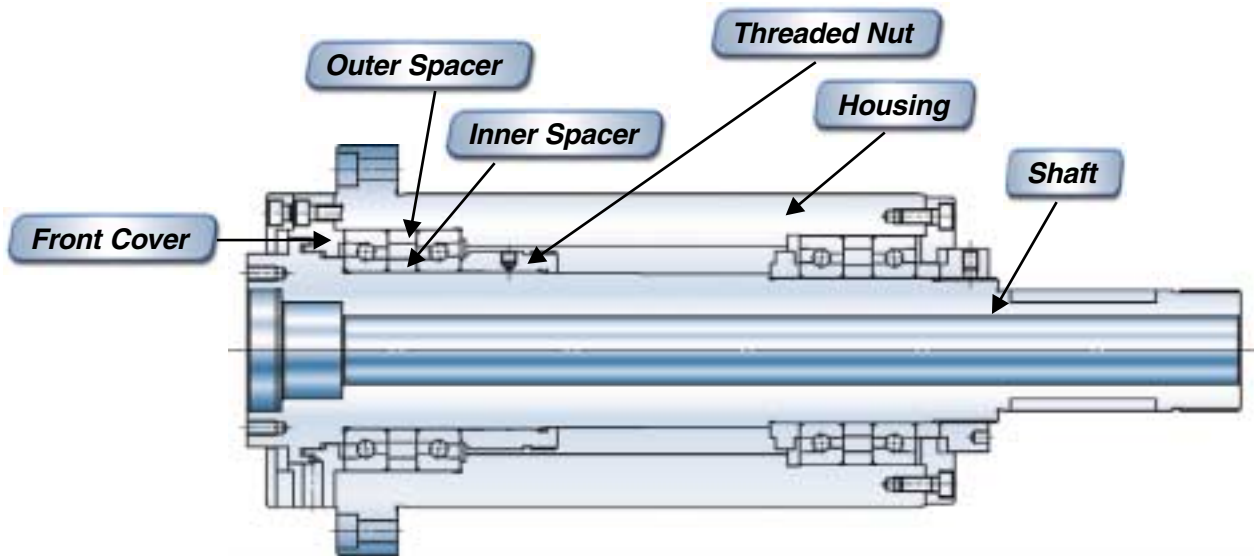

# High Speed Precision Angular Contact Ball Bearings

## Calculation of Radial Rigidity

For duplex pairs, multiply the value of axial rigidity by the factor in TABLE A.

TABLE A

	EL	L	M
18°		4.5	
25°		2	

## BNR19S, BNR19H, BNR19X Series Preloads and Axial Rigidity for Duplex Bearings

Bearing bore diameter	BNR19S (18°, steel ball)						BNR19H, BNR19X (18°, ceramic ball)					
	EL		L		M		EL		L		M	
	Preload (N)	Axial Rigidity (N/μm)	Preload (N)	Axial Rigidity (N/μm)	Preload (N)	Axial Rigidity (N/μm)	Preload (N)	Axial Rigidity (N/μm)	Preload (N)	Axial Rigidity (N/μm)	Preload (N)	Axial Rigidity (N/μm)
25	25	26	94	43	188	57	25	29	105	51	210	67
30	50	36	100	48	200	63	50	40	110	55	220	72
35	50	37	140	55	280	73	50	41	150	64	300	83
40	50	38	140	57	280	74	50	42	160	66	320	87
45	50	41	150	62	300	82	50	45	170	72	340	95
50	50	44	160	68	320	89	50	49	180	78	360	103
55	50	46	170	71	340	94	50	51	180	82	360	106
60	50	47	170	74	340	97	50	52	190	85	380	112
65	50	50	180	79	360	104	50	55	200	91	400	120
70	50	50	180	80	360	104	50	56	200	92	400	120
75	50	52	180	83	460	117	50	58	200	96	525	137
80	50	53	190	86	474	121	50	59	210	99	542	142
85	50	54	190	88	646	138	50	61	210	100	744	162
90	100	75	280	110	709	154	100	83	310	130	804	180
95	100	76	290	110	768	163	100	85	310	130	873	190
100	100	72	330	110	871	161	100	81	360	130	994	188
105	100	74	330	120	898	166	100	83	370	130	1026	194
110	100	76	400	130	925	172	100	85	450	150	1058	201
120	100	78	410	130	1275	198	100	87	460	150	1469	233
130	100	80	712	160	1408	209	100	90	809	158	1625	245
140	100	82	732	160	1508	220	100	92	833	195	1744	259
150	200	110	930	185	1894	242	200	120	1040	214	2166	284

## Calculation for Multiple Bearing Sets

For triplex or quad sets, multiply the value of preload or axial rigidity for duplex pairs by the factor in TABLE B.

For radial rigidity of triplex or quad sets, first multiply the value of axial rigidity for duplex pairs by the factor in TABLE A. Then multiply this value by the factor in TABLE B.

TABLE B

	DBD	DBB
Preload	1.36	2
Axial Rigidity	1.48	2
Radial Rigidity	1.54	2

## BER19S, BER19H, BER19X Series

Bearing bore diameter	BER19S (25°, steel ball)						BER19H, BER19X (25°, ceramic ball)					
	EL		L		M		EL		L		M	
	Preload (N)	Axial Rigidity (N/μm)	Preload (N)	Axial Rigidity (N/μm)	Preload (N)	Axial Rigidity (N/μm)	Preload (N)	Axial Rigidity (N/μm)	Preload (N)	Axial Rigidity (N/μm)	Preload (N)	Axial Rigidity (N/μm)
25	25	42	150	80	300	105	25	47	112	96	342	124
30	50	58	160	90	320	116	50	65	180	100	360	134
35	50	61	210	100	420	132	50	68	240	120	480	153
40	50	63	220	110	440	137	50	70	250	120	500	160
45	50	67	240	120	480	152	50	75	260	140	520	174
50	50	72	250	130	500	164	50	80	280	150	560	190
55	50	75	260	140	520	174	50	84	300	160	600	203
60	50	78	270	140	540	181	50	87	300	160	600	209
65	50	82	290	150	580	196	50	92	320	180	640	225
70	50	83	290	150	598	198	50	93	330	180	689	233
75	50	86	300	160	619	206	50	96	340	190	713	243
80	50	88	310	170	639	214	50	98	350	190	738	252
85	50	90	310	170	889	245	50	100	360	200	1032	290
90	100	120	430	210	968	273	100	140	480	240	1110	321
95	100	130	440	210	996	282	100	140	490	250	1143	332
100	100	120	520	210	1131	279	100	130	580	250	1302	328
105	100	120	530	220	1169	290	100	140	600	260	1246	341
110	100	130	550	230	1206	301	100	140	620	260	1390	354
120	100	130	680	250	1743	351	100	150	780	300	2023	414
130	100	135	972	289	1880	368	100	150	1115	340	2185	434
140	100	135	1002	300	1944	381	100	150	1151	353	2261	450
150	200	175	1308	336	2555	428	200	198	1484	393	2948	504



# BNR/BER ROBUST Series

## Calculation of Radial Rigidity

For duplex pairs, multiply the value of axial rigidity by the factor in TABLE A.

TABLE A

	EL	L	M
18°		4.5	
25°		2	

## BNR10S, BNR10H, BNR10X Series

### Preloads and Axial Rigidity for Duplex Bearings

Bearing bore diameter	BNR10S (18°, steel ball)						BNR10H, BNR10X (18°, ceramic ball)					
	EL		L		M		EL		L		M	
	Preload (N)	Axial Rigidity (N/μm)	Preload (N)	Axial Rigidity (N/μm)	Preload (N)	Axial Rigidity (N/μm)	Preload (N)	Axial Rigidity (N/μm)	Preload (N)	Axial Rigidity (N/μm)	Preload (N)	Axial Rigidity (N/μm)
30	50	39	110	52	220	69	50	43	110	59	220	79
35	50	41	110	55	220	73	50	46	120	63	240	83
40	50	44	110	60	220	77	50	49	120	68	240	88
45	50	44	110	60	220	77	50	49	120	69	240	88
50	50	47	120	64	249	85	50	52	130	73	279	99
55	50	48	120	67	302	95	50	54	130	76	341	110
60	50	51	130	71	345	104	50	57	140	82	391	121
65	50	53	130	75	364	111	50	60	140	87	413	130
70	50	53	230	93	505	125	50	59	260	110	578	147
75	50	54	240	96	520	129	50	61	270	110	597	151
80	100	71	330	110	606	141	100	80	360	130	684	164
85	100	73	330	110	622	145	100	82	370	130	703	169
90	100	74	340	120	823	163	100	83	370	130	938	191
95	100	76	350	120	846	168	100	85	380	140	965	197
100	100	78	350	120	870	174	100	87	390	140	993	204
105	100	80	420	130	1054	195	100	89	470	160	1209	229
110	100	81	540	150	1144	200	100	91	600	170	1315	235
120	100	85	560	160	1208	213	100	95	630	180	1391	250
130	100	85	732	166	1508	220	100	95	833	195	1745	260
140	200	105	775	178	1606	236	200	125	860	206	1829	276
150	200	110	916	190	1917	253	200	125	1025	221	2194	297

### Calculation for Multiple Bearing Sets

For triplex or quad sets, multiply the value of preload or axial rigidity for duplex pairs by the factor in TABLE B.

For radial rigidity of triplex or quad sets, first multiply the value of axial rigidity for duplex pairs by the factor in TABLE A. Then multiply this value by the factor in TABLE B.

TABLE B

	DBD	DBB
Preload	1.36	2
Axial Rigidity	1.48	2
Radial Rigidity	1.54	2

## BER10S, BER10H, BER10X Series

Bearing bore diameter	BER10S (25°, steel ball)						BER10H, BER10X (25°, ceramic ball)					
	EL		L		M		EL		L		M	
	Preload (N)	Axial Rigidity (N/μm)	Preload (N)	Axial Rigidity (N/μm)	Preload (N)	Axial Rigidity (N/μm)	Preload (N)	Axial Rigidity (N/μm)	Preload (N)	Axial Rigidity (N/μm)	Preload (N)	Axial Rigidity (N/μm)
30	50	63	220	110	440	140	50	71	250	130	500	163
35	50	67	240	120	480	153	50	75	260	140	520	175
40	50	72	250	130	500	165	50	80	280	150	560	191
45	50	73	250	130	500	166	50	81	280	150	560	192
50	50	77	270	140	540	180	50	86	300	160	600	208
55	50	80	350	160	700	205	50	89	400	190	800	240
60	50	84	380	170	760	222	50	94	430	200	860	260
65	50	88	400	180	800	235	50	99	450	210	900	275
70	50	88	400	180	800	235	50	98	450	210	900	275
75	50	90	510	200	1020	263	50	100	580	240	1160	306
80	100	120	620	220	1240	290	100	130	700	260	1400	336
85	100	120	640	230	1280	300	100	130	720	270	1440	347
90	100	120	650	240	1300	305	100	140	740	280	1480	355
95	100	130	670	240	1340	316	100	140	760	290	1520	367
100	100	130	690	250	1380	327	100	150	780	300	1560	381
105	100	130	910	290	1820	369	100	150	1040	330	2080	430
110	100	130	930	290	1860	379	100	150	1060	340	2120	440
120	100	140	980	310	1960	403	100	160	1120	370	2240	469
130	100	140	1002	310	2004	389	100	160	1150	370	2302	469
140	200	180	1098	325	2196	421	200	200	1240	380	2476	489
150	200	180	1274	345	2562	444	200	200	1444	403	2957	552

# Tolerances and Permissible Values for Angular Contact Ball Bearings

## Inner Rings (Class 4)

Units :  $\mu\text{m}$

$d$ (mm)		$\Delta_{dmp}$		$\Delta_{ds}$		$V_{dp}$		$V_{dmp}$	$K_{ia}$	$S_d$	$S_{ia}$	$\Delta_{Bs}$			$V_{Bs}$
						Diameter Series						Combined Single Brgs	Single Brg	Combined Brgs <sup>(1)</sup>	
over	incl	high	low	high	low	9	0&2	max	max	max	max				high
2.5	10	0	-4	0	-4	4	3	2	2.5	3	3	0	-40	-250	2.5
10	18	0	-4	0	-4	4	3	2	2.5	3	3	0	-80	-250	2.5
18	30	0	-5	0	-5	5	4	2.5	3	4	4	0	-120	-250	2.5
30	50	0	-6	0	-6	6	5	3	4	4	4	0	-120	-250	3
50	80	0	-7	0	-7	7	5	3.5	4	5	5	0	-150	-250	4
80	120	0	-8	0	-8	8	6	4	5	5	5	0	-200	-380	4
120	180	0	-10	0	-10	10	8	5	6	6	7	0	-250	-380	5
180	250	0	-12	0	-12	12	9	6	8	7	8	0	-300	-500	6

## Inner Rings (Class 4Y)<sup>(2)</sup>

Units :  $\mu\text{m}$

$d$ (mm)		$\Delta_{dmp}$		$\Delta_{ds}$		$V_{dp}$		$V_{dmp}$	$K_{ia}$	$S_d$	$S_{ia}$	$\Delta_{Bs}$			$V_{Bs}$
						Diameter Series						Combined Single Brgs	Single Brg	Combined Brgs <sup>(1)</sup>	
over	incl	high	low	high	low	9	0&2	max	max	max	max				high
30	50	-1	-3	-1	-3	6	5	3	4	4	4	0	-120	-250	3
50	80	-2	-5	-2	-5	7	5	3.5	4	5	5	0	-150	-250	4
80	120	-3	-6	-3	-6	8	6	4	5	5	5	0	-200	-380	4
120	150	-3	-7	-3	-7	10	8	5	6	6	7	0	-250	-380	5

## Inner Rings (Special Class 3)<sup>(3)</sup>

Units :  $\mu\text{m}$

$d$ (mm)		$\Delta_{dmp}$		$\Delta_{ds}$		$V_{dp}$	$V_{dmp}$	$K_{ia}$	$S_d$	$S_{ia}$	$\Delta_{Bs}$			$V_{Bs}$	
											Combined Single Brgs	Single Brg	Combined Brgs <sup>(1)</sup>		
over	incl	high	low	high	low	max	max	max	max	max				high	low
2.5	10	0	-4	0	-4	2.5	1.5	1.5	1.5	1.5	1.5	0	-40	-250	1.5
10	18	0	-4	0	-4	2.5	1.5	1.5	1.5	1.5	1.5	0	-80	-250	1.5
18	30	0	-5	0	-5	2.5	1.5	2.5	1.5	2.5	2.5	0	-120	-250	1.5
30	50	0	-6	0	-6	2.5	1.5	2.5	1.5	2.5	2.5	0	-120	-250	1.5
50	80	0	-7	0	-7	4	2	2.5	1.5	2.5	2.5	0	-150	-250	1.5
80	120	0	-8	0	-8	5	2.5	2.5	2.5	2.5	2.5	0	-200	-380	2.5
120	150	0	-10	0	-10	7	3.5	2.5	2.5	2.5	2.5	0	-250	-380	2.5
150	180	0	-10	0	-10	7	3.5	5	4	5	5	0	-250	-380	4
180	250	0	-12	0	-12	8	4	5	5	5	5	0	-300	-500	5

## Inner Rings (Class 2)

Units :  $\mu\text{m}$

$d$ (mm)		$\Delta_{dmp}$		$\Delta_{ds}$		$V_{dp}$	$V_{dmp}$	$K_{ia}$	$S_d$	$S_{ia}$	$\Delta_{Bs}$			$V_{Bs}$	
											Combined Single Brgs	Single Brg	Combined Brgs <sup>(1)</sup>		
over	incl	high	low	high	low	max	max	max	max	max				high	low
2.5	10	0	-2.5	0	-2.5	2.5	1.5	1.5	1.5	1.5	1.5	0	-40	-250	1.5
10	18	0	-2.5	0	-2.5	2.5	1.5	1.5	1.5	1.5	1.5	0	-80	-250	1.5
18	30	0	-2.5	0	-2.5	2.5	1.5	2.5	1.5	2.5	2.5	0	-120	-250	1.5
30	50	0	-2.5	0	-2.5	2.5	1.5	2.5	1.5	2.5	2.5	0	-120	-250	1.5
50	80	0	-4	0	-4	4	2	2.5	1.5	2.5	2.5	0	-150	-250	1.5
80	120	0	-5	0	-5	5	2.5	2.5	2.5	2.5	2.5	0	-200	-380	2.5
120	150	0	-7	0	-7	7	3.5	2.5	2.5	2.5	2.5	0	-250	-380	2.5
150	180	0	-7	0	-7	7	3.5	5	4	5	5	0	-300	-380	4
180	250	0	-8	0	-8	8	4	5	5	5	5	0	-350	-500	5

Notes (1) Applicable to single bearings manufactured for combined bearings.

(2) Class P4Y is an NSK standard with tolerances tighter than class 4.

(3) Class P3 is an NSK standard. Dimensional tolerances are class P4 and running accuracies are Class P2.

Remarks 1. The high tolerances for the bores of cylindrical-bore bearings and the low tolerances for the outside diameter are not applicable within a distance of 1.2 times the chamfer dimension  $r$  (max.) from the side of a ring.

2. The tolerances and permissible values of ABMA Standard, ABEC 7 and 9 are identical to JIS (ISO) Classes 4 and 2 respectively. The ABMA standard is applicable to angular contact ball bearings. Dimensional tolerances are class P4 and running.

# BNR/BER ROBUST Series

## Outer Rings (Class 4)

Units :  $\mu\text{m}$

$D$ (mm)		$\Delta D_{mp}$		$\Delta D_s$		$V_{Dp}$		$V_{Dmp}$	$K_{ea}$	$S_D$	$S_{ea}$	$\Delta C_s$	$V_{C_s}$
						Diameter Series							
over	incl	high	low	high	low	9	0&2	max	max	max	max	max	max
6	18	0	-4	0	-4	4	3	2	3	4	5	Same as the value of $\Delta B_s$ for the inner ring of the same bearing.	2.5
18	30	0	-5	0	-5	5	4	2.5	4	4	5		2.5
30	50	0	-6	0	-6	6	5	3	5	4	5		2.5
50	80	0	-7	0	-7	7	5	3.5	5	4	5		3
80	120	0	-8	0	-8	8	6	4	6	5	6		4
120	150	0	-9	0	-9	9	7	5	7	5	7		5
150	180	0	-10	0	-10	10	8	5	8	5	8		5
180	250	0	-11	0	-11	11	8	6	10	7	10		7
250	315	0	-13	0	-13	13	10	7	11	8	10		7
315	400	0	-15	0	-15	15	11	8	13	10	13		8

## Outer Rings (Special Class 4Y)<sup>(2)</sup>

Units :  $\mu\text{m}$

$D$ (mm)		$\Delta D_{mp}$		$\Delta D_s$		$V_{Dp}$		$V_{Dmp}$	$K_{ea}$	$S_D$	$S_{ea}$	$\Delta C_s$	$V_{C_s}$
						Diameter Series							
over	incl	high	low	high	low	9	0&2	max	max	max	max	max	max
50	80	-2	-6	-2	-6	7	5	3.5	5	4	5	Same as the value of $\Delta B_s$ for the inner ring of the same bearing.	3
80	120	-2	-6	-2	-6	8	6	4	6	5	6		4
120	150	-3	-7	-3	-7	9	7	5	7	5	7		5
150	180	-3	-7	-3	-7	10	8	5	8	5	8		5
180	200	-4	-9	-4	-9	11	8	6	10	7	10		7
200	~215	-2	-9	-2	-9	11	8	6	10	7	10		7

## Outer Rings (Special Class 3)<sup>(3)</sup>

Units :  $\mu\text{m}$

$D$ (mm)		$\Delta D_{mp}$		$\Delta D_s$		$V_{Dp}$	$V_{Dmp}$	$K_{ea}$	$S_D$	$S_{ea}$	$\Delta C_s$	$V_{C_s}$
over	incl	high	low	high	low	max	max	max	max	max	max	max
6	18	0	-4	0	-4	2.5	1.5	1.5	1.5	1.5	Same as the value of $\Delta B_s$ for the inner ring of the same bearing.	1.5
18	30	0	-5	0	-5	4	2	2.5	1.5	2.5		1.5
30	50	0	-6	0	-6	4	2	2.5	1.5	2.5		1.5
50	80	0	-7	0	-7	4	2	4	1.5	4		1.5
80	120	0	-8	0	-8	5	2.5	5	2.5	5		2.5
120	150	0	-9	0	-9	5	2.5	5	2.5	5		2.5
150	180	0	-10	0	-10	7	3.5	5	2.5	5		2.5
180	250	0	-11	0	-11	8	4	7	4	7		4
250	315	0	-13	0	-13	8	4	7	5	7		5
315	400	0	-15	0	-15	10	5	8	7	8		7

## Outer Rings (Class 2)

Units :  $\mu\text{m}$

$D$ (mm)		$\Delta D_{mp}$		$\Delta D_s$		$V_{Dp}$	$V_{Dmp}$	$K_{ea}$	$S_D$	$S_{ea}$	$\Delta C_s$	$V_{C_s}$
over	incl	high	low	high	low	max	max	max	max	max	max	max
6	18	0	-2.5	0	-2.5	2.5	1.5	1.5	1.5	1.5	Same as the value of $\Delta B_s$ for the inner ring of the same bearing.	1.5
18	30	0	-4	0	-4	4	2	2.5	1.5	2.5		1.5
30	50	0	-4	0	-4	4	2	2.5	1.5	2.5		1.5
50	80	0	-4	0	-4	4	2	4	1.5	4		1.5
80	120	0	-5	0	-5	5	2.5	5	2.5	5		2.5
120	150	0	-5	0	-5	5	2.5	5	2.5	5		2.5
150	180	0	-7	0	-7	7	3.5	5	2.5	5		2.5
180	250	0	-8	0	-8	8	4	7	4	7		4
250	315	0	-8	0	-8	8	4	7	5	7		5
315	400	0	-10	0	-10	10	5	8	7	8		7

# High Speed Precision Angular Contact Ball Bearings

## BNR19S, BNR19H, BNR19X

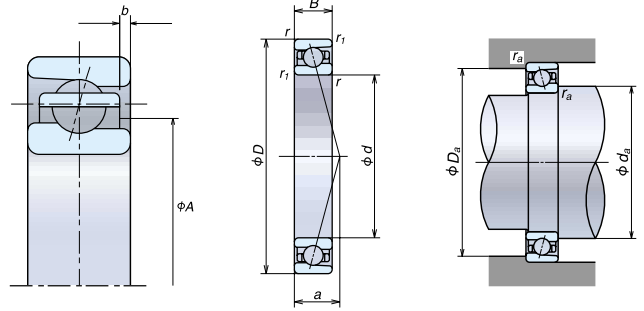

### ISO 19 series, 18° Contact Angle

Bearing Number	Boundary Dimensions (mm)					Basic Load Ratings (N)		Limiting Speed (rpm)		Nozzle Aim Point (mm)		Recommended Grease Quantity <sup>(1)</sup> (cc/row)	Effective Load Centers (mm) a	Abutment Fillet Dimensions (mm)			Mass (kg) approx.
	d	D	B	r (min)	r <sub>1</sub> (min)	C <sub>r</sub>	C <sub>0r</sub>	Grease	Oil-Air	Diameter (A)	Distance (b)			d <sub>a</sub> (min)	D <sub>a</sub> (max)	r <sub>a</sub> (max)	
25BNR19S	25	42	9	0.3	0.15	5.95	3.5	41800	59800	31	0.5	0.27	9.9	27.5	39.5	0.3	0.042
25BNR19H								53800	83600								0.038
25BNR19X								62700	98600								0.038
30BNR19S	30	47	9	0.3	0.15	6250	4050	36400	52000	35	0.5	0.31	10.8	32.5	44.5	0.3	0.048
30BNR19H								46800	72800								0.043
30BNR19X								54600	85800								0.043
35BNR19S	35	55	10	0.6	0.3	9200	6000	31200	44500	42	0.5	0.48	12.3	40	50	0.6	0.072
35BNR19H								40000	62300								0.063
35BNR19X								46700	73400								0.063
40BNR19S	40	62	12	0.6	0.3	11500	7650	27500	39300	48	0.5	0.75	14.3	45	57	0.6	0.105
40BNR19H								35300	55000								0.092
40BNR19X								41200	64800								0.092
45BNR19S	45	68	12	0.6	0.3	12100	8700	24800	35400	53	0.5	0.83	15.2	50	63	0.6	0.125
45BNR19H								31900	49600								0.111
45BNR19X								37200	58500								0.111
50BNR19S	50	72	12	0.6	0.3	12800	9750	23000	32800	57.5	0.5	0.91	15.9	55	67	1	0.127
50BNR19H								29600	46000								0.111
50BNR19X								34500	54100								0.111
55BNR19S	55	80	13	1	0.6	14400	11400	20800	29700	63.5	0.5	1.1	17.5	61	74	1	0.178
55BNR19H								26700	41500								0.158
55BNR19X								31200	48900								0.158
60BNR19S	60	85	13	1	0.6	14600	12000	19400	27600	68.5	0.5	1.2	18.3	66	79	1	0.190
60BNR19H								24900	38700								0.170
60BNR19X								29000	45600								0.170
65BNR19S	65	90	13	1	0.6	15200	13200	18100	25900	73.5	0.5	1.3	19.1	71	84	1	0.204
65BNR19H								23300	36200								0.181
65BNR19X								27100	42600								0.181
70BNR19S	70	100	16	1	0.6	21300	18100	16500	23600	80.5	0.7	2.1	21.8	76	94	1	0.328
70BNR19H								21200	33000								0.292
70BNR19X								24800	38900								0.292
75BNR19S	75	105	16	1	0.6	21600	19000	15600	22300	85	0.7	2.3	22.6	81	99	1	0.348
75BNR19H								20000	31200								0.310
75BNR19X								23400	36700								0.310
80BNR19S	80	110	16	1	0.6	22000	19900	14800	21100	90.5	0.7	2.4	23.4	86	104	1	0.366
80BNR19H								19000	29500								0.326
80BNR19X								22200	34800								0.326
85BNR19S	85	120	18	1.1	0.6	29400	26300	13700	19600	98.5	0.7	3.5	25.7	92	113	1	0.527
85BNR19H								17600	27400								0.456
85BNR19X								20500	32200								0.456
90BNR19S	90	125	18	1.1	0.6	31500	29700	13100	18700	102	0.7	3.6	26.5	97	118	1	0.552
90BNR19H								16800	26100								0.480
90BNR19X								19600	30700								0.480
95BNR19S	95	130	18	1.1	0.6	32000	31000	12500	17800	107	0.7	3.6	28.3	102	123	1	0.571
95BNR19H								16000	24900								0.497
95BNR19X								18700	29400								0.497
100BNR19S	100	140	20	1.1	0.6	38000	35000	11700	16700	113.5	0.7	4.9	29.5	107	133	1	0.770
100BNR19H								15000	23400								0.673
100BNR19X								17500	27500								0.673
105BNR19S	105	145	20	1.1	0.6	38500	36500	11200	16000	119	0.7	5.1	31.5	112	138	1	0.795
105BNR19H								14400	22400								0.693
105BNR19X								16800	26400								0.693
110BNR19S	110	150	20	1.1	0.6	39000	38000	10800	15400	124	0.7	5.2	31.1	117	143	1	0.838
110BNR19H								13900	21600								0.733
110BNR19X								16200	25400								0.733
120BNR19S	120	165	22	1.1	0.6	54000	52000	9900	14100	136	0.7	7.9	34.2	127	158	1	1.240
120BNR19H								12700	19700								0.949
120BNR19X								14800	23200								0.949

(1) NSK recommends a 15% grease fill. The values provided reflect this recommendation.

## BER19S, BER19H, BER19X

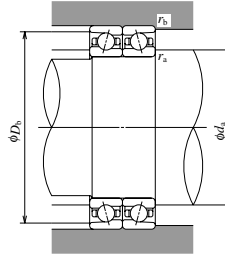

**Dynamic Equivalent Load**  $P = X F_r + Y F_a$

Nominal Contact Angle	$\frac{C_{int}}{i F_a}$	e	Single, DT				DB or DT			
			$F_r/F_a \leq e$		$F_r/F_a > e$		$F_r/F_a \leq e$		$F_r/F_a > e$	
			X	Y	X	Y	X	Y	X	Y
18°	—	0.57	1	0	0.43	1	1	1.09	0.70	1.63
25°	—	0.68	1	0	0.41	0.87	1	0.92	0.67	1.41

\*For i, use 2 for DB and DF and 1 for DT.

**Static Equivalent Load**  $P_0 = X_0 F_r + Y_0 F_a$

Nominal Contact Angle	Single, DT		DB or DF	
	$X_0$	$Y_0$	$X_0$	$Y_0$
18°	0.5	0.42	1	0.84
25°	0.5	0.38	1	0.76

Single or DT mounting when  $F_r > 0.5 F_a + Y_0 F_a$  use  $P_0 = F_r$

### ISO 19 series, 25° Contact Angle

Bearing Number	Boundary Dimensions (mm)					Basic Load Ratings (N)		Limiting Speed (rpm)		Nozzle Aim Point (mm)		Recommended Grease Quantity <sup>(1)</sup> (cc/row)	Effective Load Centers (mm) a	Abutment Fillet Dimensions (mm)			Mass (kg) approx.
	d	D	B	r (min)	r <sub>1</sub> (min)	Cr	C <sub>0r</sub>	Grease	Oil-Air	Diameter (A)	Distance (b)			d <sub>a</sub> (min)	D <sub>a</sub> (max)	r <sub>a</sub> (max)	
25BER19S	25	42	9	0.3	0.15	5.7	3.4	35900	58000	31	0.5	0.27	12.3	27.5	39.5	0.3	0.042
25BER19H								47800	74700								0.038
25BER19X								56800	89600								0.038
30BER19S	30	47	9	0.3	0.15	6000	3900	31200	44200	35	0.5	0.31	13.5	32.5	44.5	0.3	0.048
30BER19H								41600	65000								0.043
30BER19X								49400	78000								0.043
35BER19S	35	55	10	0.6	0.3	8800	5750	26700	37800	42	0.5	0.48	15.5	40	50	0.6	0.072
35BER19H								35600	55600								0.063
35BER19X								42300	66700								0.063
40BER19S	40	62	12	0.6	0.3	11000	7350	23600	33400	48	0.5	0.75	17.9	45	57	0.6	0.105
40BER19H								31400	49100								0.092
40BER19X								37300	58900								0.092
45BER19S	45	68	12	0.6	0.3	11600	8350	21300	30100	53	0.5	0.83	19.2	50	63	0.6	0.125
45BER19H								28400	44300								0.111
45BER19X								33700	53100								0.111
50BER19S	50	72	12	0.6	0.3	12300	9350	19700	27900	57.5	0.5	0.91	20.2	55	67	1	0.127
50BER19H								26300	41000								0.111
50BER19X								31200	49200								0.111
55BER19S	55	80	13	1	0.6	13800	10900	17800	25200	63.5	0.5	1.1	22.2	61	74	1	0.178
55BER19H								23800	37100								0.158
55BER19X								28200	44500								0.158
60BER19S	60	85	13	1	0.6	14000	11500	16600	23500	68.5	0.5	1.2	23.4	66	79	1	0.190
60BER19H								22100	34500								0.170
60BER19X								26300	41400								0.170
65BER19S	65	90	13	1	0.6	14500	12600	15500	22000	73.5	0.5	1.3	24.6	71	84	1	0.204
65BER19H								20700	32300								0.181
65BER19X								24600	38800								0.181
70BER19S	70	100	16	1	0.6	20400	17300	14200	20000	80.5	0.7	2.1	27.8	76	94	1	0.328
70BER19H								18900	29500								0.292
70BER19X								22400	35300								0.292
75BER19S	75	105	16	1	0.6	20700	18200	13400	18900	85	0.7	2.3	29	81	99	1	0.348
75BER19H								17800	27800								0.310
75BER19X								21200	33400								0.310
80BER19S	80	110	16	1	0.6	21000	19100	12700	17900	90.5	0.7	2.4	30.1	86	104	1	0.366
80BER19H								16900	26400								0.326
80BER19X								20000	31600								0.326
85BER19S	85	120	18	1.1	0.6	28100	25200	11800	16600	98.5	0.7	3.5	32.9	92	113	1	0.527
85BER19H								15700	24400								0.456
85BER19X								18600	29300								0.456
90BER19S	90	125	18	1.1	0.6	30000	28500	11200	15900	102	0.7	3.6	34.1	97	118	1	0.552
90BER19H								14900	23300								0.480
90BER19X								17700	28000								0.480
95BER19S	95	130	18	1.1	0.6	30500	29700	10700	15200	107	0.7	3.6	36.7	102	123	1	0.571
95BER19H								14300	22300								0.497
95BER19X								16900	26700								0.497
100BER19S	100	140	20	1.1	0.6	36000	33500	10000	14200	113.5	0.7	4.9	38	107	133	1	0.770
100BER19H								13400	20900								0.673
100BER19X								15900	25000								0.673
105BER19S	105	145	20	1.1	0.6	37000	35000	9600	13600	119	0.7	5.1	40.9	112	138	1	0.795
105BER19H								12800	20000								0.693
105BER19X								15200	24000								0.693
110BER19S	110	150	20	1.1	0.6	37500	36500	9300	13100	124	0.7	5.2	40.3	117	143	1	0.838
110BER19H								12400	19300								0.733
110BER19X								14700	23100								0.733
120BER19S	120	165	22	1.1	0.6	51500	50000	8500	12000	136	0.7	7.9	44.2	127	158	1	1.240
120BER19H								11300	17600								0.949
120BER19X								13400	21100								0.949

# High Speed Precision Angular Contact Ball Bearings

## BNR10S, BNR10H, BNR10X

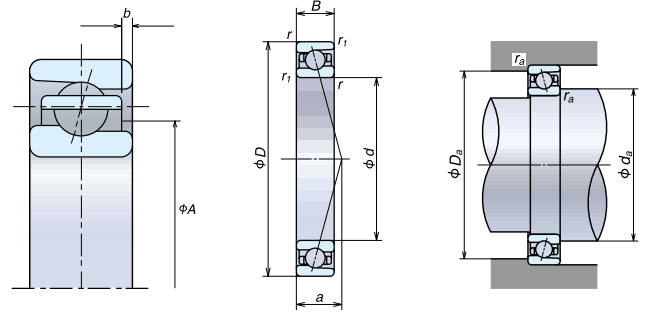

### ISO 10 series, 18° Contact Angle

Bearing Number	Boundary Dimensions (mm)					Basic Load Ratings (N)		Limiting Speed (rpm)		Nozzle Aim Point (mm)		Recommended Grease Quantity <sup>(1)</sup> (cc/row)	Effective Load Centers (mm) a	Abutment Fillet Dimensions (mm)			Mass (kg) approx.
	d	D	B	r (min)	r <sub>1</sub> (min)	C <sub>r</sub>	C <sub>0r</sub>	Grease	Oil-Air	Diameter (A)	Distance (b)			d <sub>a</sub> (min)	D <sub>a</sub> (max)	r <sub>a</sub> (max)	
30BNR10S	30	55	13	1	0.6	8650	5750	33000	47100	39	1	0.58	13.3	36	49	1	0.124
30BNR10H								42400	65900								0.116
30BNR10X								49500	77700								0.116
35BNR10S	35	62	14	1	0.6	10100	7100	28900	41300	44.5	1.2	0.78	14.8	41	56	1	0.164
35BNR10H								37200	57800								0.154
35BNR10X								43300	68100								0.154
40BNR10S	40	68	15	1	0.6	10600	7950	26000	37100	50	1.5	0.92	16.2	46	62	1	0.204
40BNR10H								33400	51900								0.193
40BNR10X								38900	61200								0.193
45BNR10S	45	75	16	1	0.6	11700	9000	23400	33400	55.5	1.7	1.2	17.6	51	69	1	0.259
45BNR10H								30000	46700								0.246
45BNR10X								35000	55000								0.246
50BNR10S	50	80	16	1	0.6	12200	9900	21600	30800	60.5	1.7	1.2	18.4	56	74	1	0.281
50BNR10H								27700	43100								0.266
50BNR10X								32400	50800								0.266
55BNR10S	55	90	18	1.1	0.6	15100	12500	19400	27600	67.5	1.5	1.7	20.6	62	83	1	0.414
55BNR10H								24900	38700								0.393
55BNR10X								29000	45600								0.393
60BNR10S	60	95	18	1.1	0.6	15600	13700	18100	25900	73	1.5	1.8	21.5	67	88	1	0.443
60BNR10H								23300	36200								0.419
60BNR10X								27100	42600								0.419
65BNR10S	65	100	18	1.1	0.6	16200	14800	17000	24300	77.5	1.5	1.9	22.3	42	93	1	0.472
65BNR10H								21900	34000								0.447
65BNR10X								25500	40000								0.447
70BNR10S	70	110	20	1.1	0.6	22300	19800	15600	22300	84	1.7	2.8	24.5	77	103	1	0.645
70BNR10H								20000	31200								0.605
70BNR10X								23400	36700								0.605
75BNR10S	75	115	20	1.1	0.6	22600	20700	14800	21100	89	1.7	2.9	25.3	82	108	1	0.679
75BNR10H								19000	29500								0.638
75BNR10X								22200	34800								0.638
80BNR10S	80	125	22	1.1	0.6	26500	24500	13700	19600	96	1.7	3.8	27.5	87	118	1	0.921
80BNR10H								17600	27400								0.867
80BNR10X								20500	32200								0.867
85BNR10S	85	130	22	1.1	0.6	26800	25700	13100	18700	102	1.7	4.0	28.4	92	123	1	0.962
85BNR10H								16800	26100								0.906
85BNR10X								19600	30700								0.906
90BNR10S	90	140	24	1.5	1	35000	33000	12200	17400	109	1.7	5.5	30.7	99	131	1.5	1.241
90BNR10H								15700	24400								1.155
90BNR10X								18300	28700								1.155
95BNR10S	95	145	24	1.5	1	35500	34500	11700	16700	112	2.5	5.7	31.3	104	136	1.5	1.298
95BNR10H								15000	23400								1.209
95BNR10X								17500	27500								1.209
100BNR10S	100	150	24	1.5	1	36000	36000	11200	16000	118.5	1.7	6.1	32.3	109	141	1.5	1.245
100BNR10H								14400	22400								1.253
100BNR10X								16800	26400								1.253
105BNR10S	105	160	26	2	1	41000	41000	10600	15100	125	1.7	7.6	34.5	115	150	2	1.698
105BNR10H								13600	21200								1.585
105BNR10X								15900	25000								1.585
110BNR10S	110	170	28	2	1	46000	47000	10000	14300	132.5	1.7	9.1	36.7	120	160	2	2.133
110BNR10H								12900	20000								1.996
110BNR10X								15000	23600								1.996
120BNR10S	120	180	28	2	1	47500	50500	9400	13400	143	1.7	9.8	38.4	130	170	2	2.286
120BNR10H								12000	18700								2.139
120BNR10X								14000	22000								2.139

(<sup>1</sup>) NSK recommends a 15% grease fill. The values provided reflect this recommendation.

# BNR/BER ROBUST Series

## BER10S, BER10H, BER10X

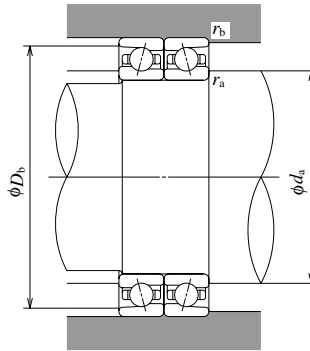

**Dynamic Equivalent Load**  $P = XF_r + YF_a$

Nominal Contact Angle	$C_{or}^*$ $iF_a$	e	Single, DT				DB or DT			
			$F_r/F_r \leq e$		$F_r/F_r > e$		$F_r/F_r \leq e$		$F_r/F_r > e$	
			X	Y	X	Y	X	Y	X	Y
18°	—	0.57	1	0	0.43	1	1	1.09	0.70	1.63
25°	—	0.68	1	0	0.41	0.87	1	0.92	0.67	1.41

\*For  $i$ , use 2 for DB and DF and 1 for DT.

**Static Equivalent Load**  $P_0 = X_0F_r + Y_0F_a$

Nominal Contact Angle	Single, DT		DB or DF		Single or DT mounting when $F_r > 0.5F_r + Y_0F_a$ use $P_0 = F_r$
	$X_0$	$Y_0$	$X_0$	$Y_0$	
18°	0.5	0.42	1	0.84	
25°	0.5	0.38	1	0.76	

### ISO 10 series, 25° Contact Angle

Bearing Number	Boundary Dimensions (mm)					Basic Load Ratings (N)		Limiting Speed (rpm)		Nozzle Aim Point (mm)		Recommended Grease Quantity <sup>(1)</sup> (cc/row)	Effective Load Centers (mm) a	Abutment Fillet Dimensions (mm)			Mass (kg) approx.
	d	D	B	r (min)	r1 (min)	Cr	$C_{0r}$	Grease	Oil-Air	Diameter (A)	Diameter (b)			$d_a$ (min)	$D_a$ (max)	$r_a$ (max)	
30BER10S	30	55	13	1	0.6	8300	5500	28300	40000	39	1	0.58	16.3	36	49	1	0.124
30BER10H								37700	58900								0.116
30BER10X								44800	70600								0.116
35BER10S	35	62	14	1	0.6	9700	6850	24800	35100	44.5	1.2	0.78	18.2	41	56	1	0.164
35BER10H								33000	51600								0.154
35BER10X								39200	61900								0.154
40BER10S	40	68	15	1	0.6	10100	7650	22300	31500	50	1.5	0.92	19.9	46	62	1	0.204
40BER10H								29700	46300								0.193
40BER10X								35200	55600								0.193
45BER10S	45	75	16	1	0.6	11200	8600	20000	28400	55.5	1.7	1.2	21.8	51	69	1	0.259
45BER10H								26700	41700								0.246
45BER10X								31700	50000								0.246
50BER10S	50	80	16	1	0.6	11600	9500	18500	26200	60.5	1.7	1.2	23	56	74	1	0.281
50BER10H								24700	38500								0.266
50BER10X								29300	46200								0.266
55BER10S	55	90	18	1.1	0.6	14400	12000	16600	23500	67.5	1.5	1.7	25.7	62	83	1	0.414
55BER10H								22100	34500								0.393
55BER10X								26300	41400								0.393
60BER10S	60	95	18	1.1	0.6	15000	13100	15500	22000	73	1.5	1.8	26.9	67	88	1	0.443
60BER10H								20700	32300								0.419
60BER10X								24600	38800								0.419
65BER10S	65	100	18	1.1	0.6	15500	14200	14600	20700	77.5	1.5	1.9	28	42	93	1	0.472
65BER10H								19400	30400								0.447
65BER10X								23100	36400								0.447
70BER10S	70	110	20	1.1	0.6	21300	18900	13400	18900	84	1.7	2.8	30.8	77	103	1	0.645
70BER10H								17800	27800								0.605
70BER10X								21200	33400								0.605
75BER10S	75	115	20	1.1	0.6	21600	19800	12700	17900	89	1.7	2.9	31.9	82	108	1	0.679
75BER10H								16900	26400								0.638
75BER10X								20000	31600								0.638
80BER10S	80	125	22	1.1	0.6	25300	23500	11800	16600	96	1.7	3.8	34.6	87	118	1	0.921
80BER10H								15700	24400								0.867
80BER10X								18600	29300								0.867
85BER10S	85	130	22	1.1	0.6	25600	24600	11200	15900	102	1.7	4.0	36.1	92	123	1	0.962
85BER10H								14900	23300								0.906
85BER10X								17700	28000								0.906
90BER10S	90	140	24	1.5	1	33500	31500	10500	14800	109	1.7	5.5	38.8	99	131	1.5	1.241
90BER10H								14000	21800								1.155
90BER10X								16600	26100								1.155
95BER10S	95	145	24	1.5	1	34000	33000	10000	14200	112	2.5	5.7	39.7	104	136	1.5	1.298
95BER10H								13400	20900								1.209
95BER10X								15900	25000								1.209
100BER10S	100	150	24	1.5	1	34500	34500	9600	13600	118.5	1.7	6.1	41.2	109	141	1.5	1.245
100BER10H								12800	20000								1.253
100BER10X								15200	24000								1.253
105BER10S	105	160	26	2	1	39000	39500	9100	12900	125	1.7	7.6	43.9	115	150	2	1.698
105BER10H								12100	18900								1.585
105BER10X								14400	22700								1.585
110BER10S	110	170	28	2	1	44000	45000	8600	12200	132.5	1.7	9.1	46.7	120	160	2	2.133
110BER10H								11500	17900								1.996
110BER10X								13600	21500								1.996
120BER10S	120	180	28	2	1	45500	48500	8000	11400	143	1.7	9.8	49	130	170	2	2.286
120BER10H								10700	16700								2.139
120BER10X								12700	20000								2.139



## Worldwide Sales Offices

<b>NSK Ltd. - Headquarters, Tokyo, Japan</b>	<a href="http://www.nsk.com">www.nsk.com</a>	<b>New Zealand:</b>	<a href="http://www.nsk.co.nz">www.nsk.co.nz</a>	<b>Turkey:</b>	
Americas & Europe Department	tel: 03-3779-7120	NSK New Zealand Ltd.		NSK Bearings Middle East Trading Co., Ltd.	
Asia Marketing & Sales Department	tel: 03-3779-7121	Auckland	tel: (09) 276-4992	Istanbul	tel: 90-216-442-7106
<b>Africa</b>		<b>Philippines:</b>		<b>United Kingdom:</b>	
<b>South Africa:</b>		NSK representative office	tel: 02-759-6246	NSK Bearings Europe Ltd.	
NSK South Africa (Pty) Ltd.		Manila		Peterlee, England	tel: 0191-586-6111
Johannesburg	tel: (011) 458 3600	<b>Singapore:</b>		NSK European Technology Center., Ltd.	
<b>Asia and Oceania</b>		NSK International (Singapore) Pte Ltd.	tel: (65) 273 0357	Newark, England	tel: 0163-660-5123
<b>Australia:</b>	<a href="http://www.nskaustralia.com.au">www.nskaustralia.com.au</a>	Singapore		NSK UK Ltd.	tel: 0163-660-5123
NSK Australia Pty. Ltd.		NSK Singapore (Pte) Ltd.	tel: (65) 278 1711	Newark, England	
Melbourne	tel: (03) 9764-8302	Singapore		NSK Steering Systems Europe Ltd.	tel: 024-76-588588
<b>China:</b>		<b>Taiwan:</b>		<b>North and South America</b>	
NSK Hong Kong Ltd.	<a href="http://www.cn.nsk.com">www.cn.nsk.com</a>	Taiwan NSK Precision Co., Ltd.	tel: 02-2591-0656	<b>NSK Americas, Inc. (American Headquarters)</b>	
Hong Kong	tel: 2 7 3 9 - 9 9 3 3	Taipei		Ann Arbor, Michigan, U.S.A.	tel: 734-913-7500
Kunshan NSK Co., Ltd.		<b>Thailand:</b>		<b>Argentina:</b>	
Kunshan	tel: 0520-7305654	NSK Bearings (Thailand) Co., Ltd.	tel: 02-6412150-58	NSK Argentina SRL	tel: 011-4762-6556
Guizhou HS NSK Bearings Co., Ltd.		Bangkok	tel: (038) 214-317-8	Buenos Aires	<a href="http://www.br.nsk.com">www.br.nsk.com</a>
Anshun	tel: 0853-3521505	Chonburi		<b>Brazil:</b>	
NSK (Shanghai) Trading Co., Ltd.	tel: 021-62099051	SNNs Co., Ltd.	tel: (038) 522-343-350	NSK Brasil Ltda.	
Shanghai		Chachoengsao		São Paulo	tel: 011-3269-4700
NSK representative office	tel: 010-6590-8161	<b>Europe</b>		<b>Canada:</b>	<a href="http://www.ca.nsk.com">www.ca.nsk.com</a>
NSK representative office	tel: 21-6209-9051	<b>NSK Europe Ltd.</b>		NSK Canada Inc.	tel: 905-890-0740
NSK representative office	tel: 020-8732-0583	<b>(European Headquarters)</b>	<a href="http://www.eu.nsk.com">www.eu.nsk.com</a>	Toronto	
NSK representative office	tel: 0853-3522522	Maidenhead, England	tel: 0162-850-9800	<b>Mexico:</b>	
<b>India:</b>		<b>France:</b>		NSK Rodamientos Mexicana, S.A. de C.V.	tel: 5-301-2741
Rane NASTECH Ltd.		NSK France S.A.	tel: 01 30 57 39 39	Mexico City	
Chennai	tel: 04114-65313, 65314, 65365, 66002	Paris		<b>United States of America:</b>	<a href="http://www.us.nsk.com">www.us.nsk.com</a>
NSK representative office		<b>Germany:</b>		NSK Corporation	
Chennai	tel: 044-4334732	NSK Deutschland GmbH	tel: 02102-481-0	Ann Arbor, Michigan	tel: 734-913-7500
<b>Indonesia:</b>		NSK Steering Systems Europe Ltd.	tel: 0771-79082-277	Sales Offices:	
PT.NSK Bearings Manufacturing Indonesia		Stuttgart		Ann Arbor, Michigan	tel: 734-913-7500
Jakarta	tel: 021-898-0155	Neuweg Fertigung GmbH	tel: 0 7 3 9 3 - 5 4 0	Cerritos, California	tel: 562-926-2975
<b>Korea:</b>	<a href="http://www.kr.nsk.com">www.kr.nsk.com</a>	Munderkingen		NSK American Technical Center	tel: 734-913-7500
NSK Korea Co., Ltd.		<b>Italy:</b>		Ann Arbor, Michigan	
Seoul	tel: 02-3287-0300	NSK Italia S.P.A.	tel: 02-995-191	NSK Precision America, Inc.	<a href="http://www.npa.nsk.com">www.npa.nsk.com</a>
NSK Korea Co., Ltd., Changwon Plant		Milano		Addison, Illinois	tel: 630-620-8500
Changwon	tel: 0551-287-6001	<b>Poland:</b>		NSS America	
<b>Malaysia:</b>		NSK Europe Ltd. Warsaw Liaison Office	tel: 48-22-645-1525, 1526	Bennington, Vermont	tel: 802-442-5448
NSK Bearings (Malaysia) Sdn. Bhd.		Warsaw		NSK Latin America Inc.	<a href="http://www.la.nsk.com">www.la.nsk.com</a>
Kuala Lumpur	tel: 03-7958-4396	NSK Iskra S.A.	tel: 48-41-366-6111	Miami, Florida	tel: (305) 477-0605
NSK Micro Precision (M) Sdn. Bhd.		Kielce			
Kuala Lumpur	tel: 03-961-6288	<b>Spain:</b>			
		NSK Spain S.A.	tel: 93-575-4041		
		Barcelona			

NSK Ltd. has a basic policy not to export any products or technology designated as controlled items by export-related laws. When exporting the products in this brochure, the laws of the exporting country must be observed. Specifications are subject to change without notice and without any obligation on the part of the manufacturer. Every care has been taken to ensure the accuracy of the data contained in this brochure, but no liability can be accepted for any loss or damage suffered through errors or omissions. We will gratefully acknowledge any additions or corrections.