

SPACEA™ Series SJ Bearings for High Temperatures

Outstanding performance in normal atmospheric and vacuum environments up to 400°C



Patent Pending



SPACEA™ Series SJ Bearings for High Temperatures

How do SJ bearings achieve high performance and maintenance-free operation?

Resembling a peapod, the cage pocket of SJ bearings contains a solid lubricant spacer joint positioned between two specially treated balls. This groundbreaking technology overcomes the problems of high-temperature environments and achieves extended maintenance-free performance.

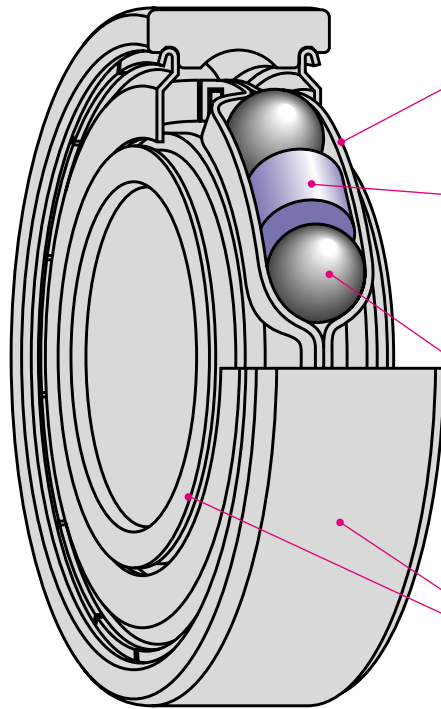

Special cage

Pressed austenitic stainless steel or cold-rolled steel are standard.

Solid lubricant spacer joint

Sintered molybdenum disulfide-based material ensures effective lubrication up to 400°C in normal and vacuum environments.

Ball

A coating of the material used for the spacer joints is applied to the balls, which are made of martensitic stainless steel, bearing steel or, for extended durability, ceramics.

Bearing outer and inner rings

Martensitic stainless steel and bearing steel are available as standard.

Features

1

Long life

Long life is achieved with the steady supply of lubricant supplied by the spacer joint. Durability in high-temperature atmospheric conditions is six times longer than bearings with conventional solid lubricant paste.

2

High-temperature compatibility

Molybdenum disulfide ensures serviceability in temperatures up to 400°C in normal and vacuum environments.

3

Excellent torque stability

Excellent torque stability is realized by the steady flow of lubricant from the spacer joints and by coating the balls with the same molybdenum disulfide-based material used for the spacer joints.

Major applications

Vacuum deposition equipment

Kilns

Kiln cars

Iron shops

Conveyors for high-temperature normal and vacuum environments

Availability

Bearing types	Deep groove ball bearings, ball bearing units and angular contact ball bearings
Size	Bore diameter ϕ 8 mm or more (Outside diameters up to ϕ 250 mm approx.)
Basic numbers	608; 6000, 6001, 6002, 6003, 6004; 6200, 6201, 6202, 6203
Maximum temperature	400°C
Permissible load	As a general rule, 5% of basic dynamic load rating
Permissible rotating speed	As a general rule, 100,000 $d_m n$ *

$$*d_m n = [\text{bearing bore diameter (mm)} + \text{bearing outside diameter (mm)}] \div 2 \times \text{rotating speed (rpm)}$$

Test Results

1. Performance in normal atmospheric conditions

Durability is six times that of conventional bearings with solid lubricant paste and twice that of spacer joint bearings without cages.

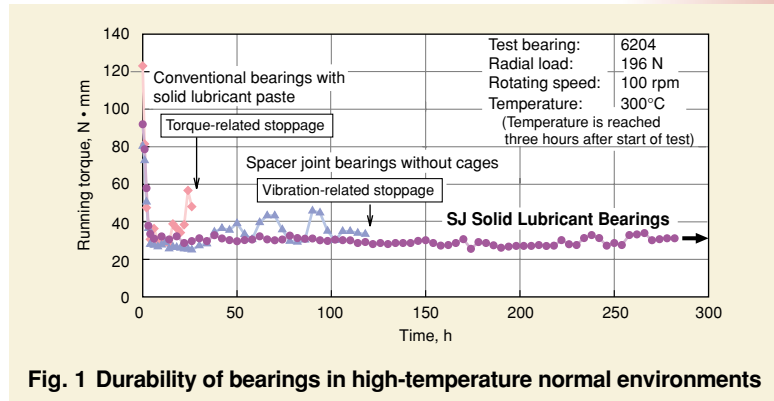

2. Performance in vacuum conditions

Even in a vacuum, durability and torque stability exceed conventional silver-coated bearings.

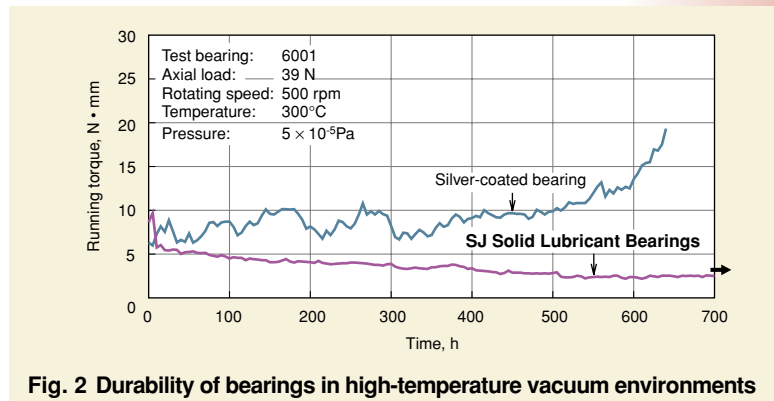

3. Outgassing in vacuum conditions

Eliminating concerns over product pollution, the solid lubricant spacer joints demonstrate minimal outgassing.

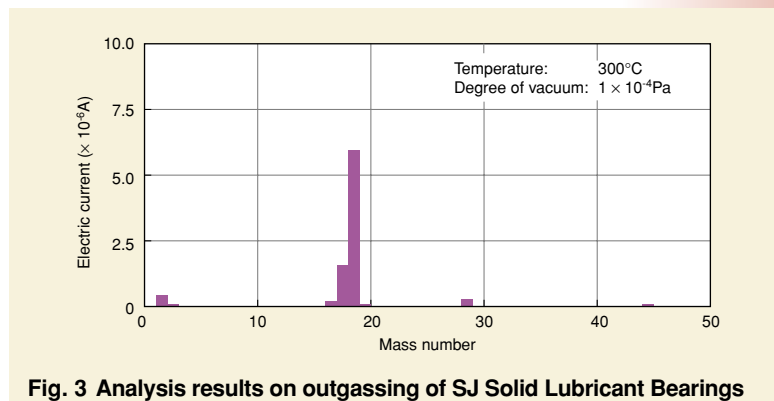

Bearing Nomenclature

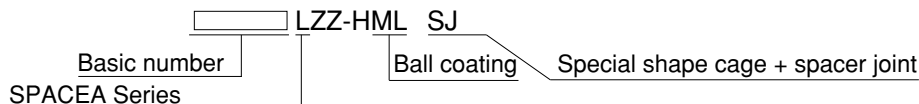

Note: Depending on the bearing number, other SPACEA Series products may meet requirements. Please contact NSK for further details.